

GLASSHOUSE VERSAILLES

WIDTH 2.80 M

ON LOW WALL OR BASEPLATE
40 OR 87 CM HIGH

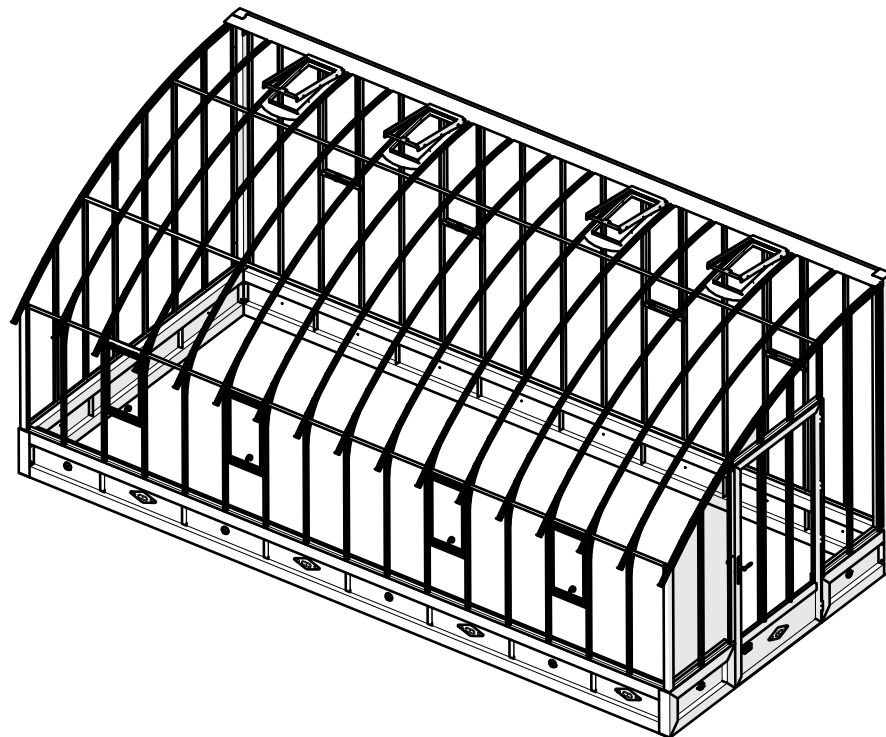
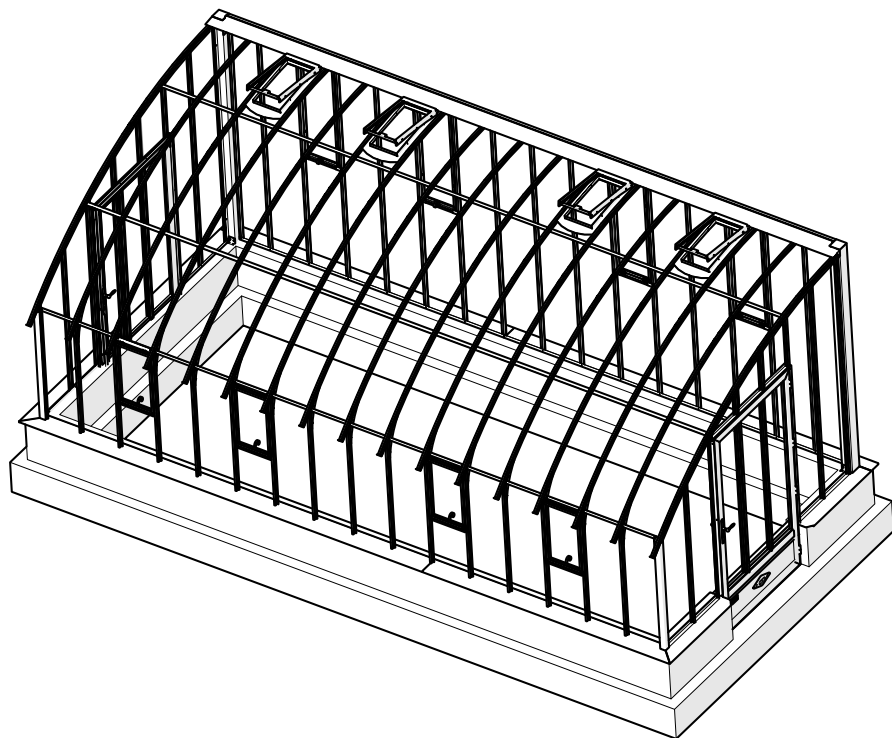

LAMS

Créateur & Fabricant Français de serres depuis 1993

CONTENS

• Recommendations	03-04
• List of small parts	05
• List of profiles	06
• Location of the profiles	07
• Masonry plan for the low wall	08
• Assembling the poles and roof ridge on the ground	09
• Positioning and fixing the aluminium coping - Glasshouse on low wall	10
• Positioning and fixing the aluminium coping and door frame - Glasshouse on low wall.....	11
• Masonry plan for the concrete blocks	12
• Masonry plan for the concrete frame and slab	13
• Assembling the poles and roof ridge on the ground	14
• Assembling the aluminium baseplate, the door frame and the poles with the ridge	15
• Fixing the baseplate to the ground	16
• Installing the seal on the roof profiles	18
• Installing the wall corner profiles	19
• Installing the curved exterior roof profile	20
• Installing the front wall profile	21
• Installing the back wall and gable profile	22
• Installing the curved roof profiles - Fixing the upper part	23
• Installing the curved roof profiles - Fixing the lower part	24
• Installing the roof beams	25
• Installing the door and roof windows	26
• Installing the wall windows	27
• Installing the wall and roof glazing - Ridge height 2,70 m	28
• Installing the wall and roof glazing - Ridge height 3,10 m	29
• Installing the roof glazing - Small glass panes (glass tiles)	30
• Finishing touches	31
• Option - Shading system	32

RECOMMENDATIONS



IMPORTANT

Remember to declare your glasshouse to your insurer.

Please read the following instructions carefully before you start assembling your glasshouse.

Verify that the delivery box contains all the components referred to in this instruction manual and check their quantities.

Follow the assembly steps in the order given in this instruction manual.

Some profiles show small 3mm DIAM holes. These small holes were meant for hanging the profiles in the paint booth and are of no use for assembly itself.

SAFETY WARNINGS

Please wear safety gloves, shoes and glasses.

Follow the safety instructions for each of the other tools you will be using.

Do not assemble your glasshouse in adverse weather conditions (rain, wind, storm...).

The glasshouse should be assembled by 2 people.

Position your glasshouse on a flat level area.

For a glasshouse on a low wall : observe the outer measurements given and the squaring of the wall (see masonry plan).

For a lean-to glasshouse : the lean-to wall must be plumb (see masonry plan).

The plastic bags and small components are not toys. Keep them away from children's reach. Keep children away from the assembly area.

Aluminium conducts electricity. The aluminium profiles should not be in contact with any source of power.

Do not store any heat-generating device in the glasshouse (barbecue, blowtorch etc...).

Do not mount or install your glasshouse over water, electricity or gas underground networks.

Do not climb on the glasshouse roof : risk of serious injuries.

In case of heavy snow : do not leave a thick layer on the roof.

MAINTENANCE TIPS

Use soapy water and a cloth to clean your glasshouse. Do not use acetone or detergents.

Use the high-pressure cleaner from a safe distance.

Lubricate the hinges, window restrictors and locks on a regular basis.

Regularly tighten up the roof wind braces. Do not leave snow or tree leaves on the roof.

CUSTOMER SERVICE & INFORMATION

Please fill in the contact form on our website www.lams-greenhouse.com

RECOMMANDATIONS

INCLUDED TOOLS AND ACCESSORIES



Combination wrench & Ø 10 socket spanner



Automatic screwdriver ends Ø 10 & cruciform



Suction cup for glazing



Translucent silicon



Gloves



Thermometer

NECESSARY TOOLS

- Spirit level
- Tape measure
- Rubber mallet
- Pair of scissors (to cut rubber seal)
- Cross point screwdriver
- Wrench Ø 8 mm (for leaf-motif moulding and logo plate)
- Wrench Ø 10 mm
- Automatic screwdriver
- Plumb bob
- Set square
- Stepladder

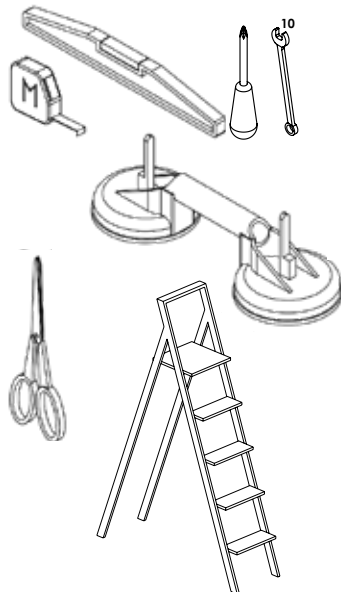

Ø 8 mm

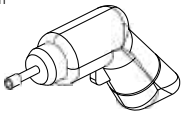

HOW TO ASSEMBLE THE SECTIONS



The flange nut M6 (5), the stainless steel screws (3), hammer-head and Hex-head are fundamental for the assembly.

In the first steps of assembly, use Hex-head screws (3) preferably. In the instruction manual, you will mostly see pictures of hammerhead screws (3) but you may use either hammerhead screws or Hex-head screws when (3) is specified.

You can insert hammerhead screws in the profile slots at any stage of the assembly. However, make sure hammer-head screws are properly fastened so that they don't fall off.

There's a slot in the hammerhead screw end. When the slot is perpendicular to the profile (diagram A), then the screw is in the best position.

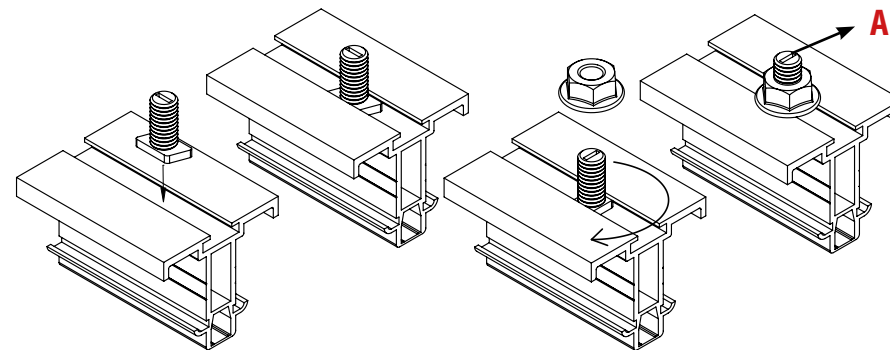

Horizontal imprint

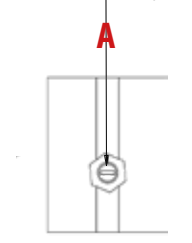



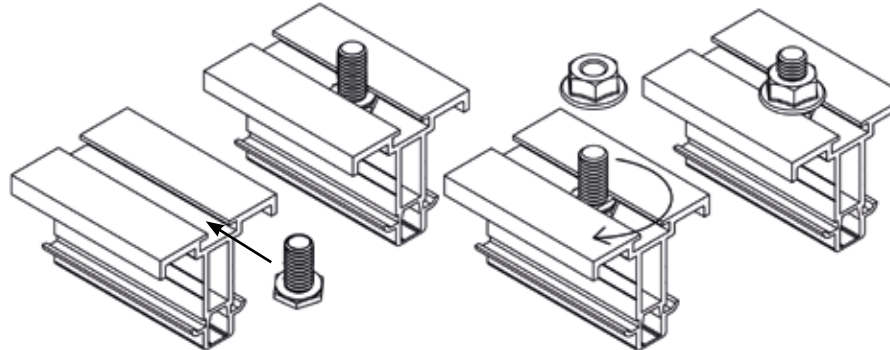



















Put the Hex-head screw (3) in the profile slot so that it stays in place.



LIST OF SMALL PARTS

Part identification

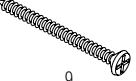





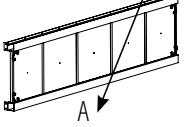

The number on the instructions enables the part to be identified in the event of an exchange between you and customer service.

Part detail	Reference	Part detail	Reference	Part detail	Reference
<i>Pole fixing bracket</i>  1	787911	<i>Countersunk screw M6x20</i>  12	365418	<i>S glazing hooks</i>  44	365373
<i>Hex-head flange screw M6x20</i>  2	789300	<i>Leaf moulding</i>  16	363235	<i>W glazing clip</i>  SAL1	366419
<i>Hammerhead screw M6x12</i> <i>Hex-head screw M6x12</i>  3	365401 994778	<i>LAMS logo</i>  17	794995	<i>Rose moulding</i>  SAL2	364224
<i>Hammerhead screw M6x20</i>  4	608010	<i>Hex-head screw M5x8mm</i>  18	364408	<i>Wall foundry bracket</i>  SAL3	607857
<i>Flange nut M6</i>  5	789280	<i>Black plastic nut cover M5</i>  19	787551		
<i>Black plastic nut cover M6</i>  6	365483	<i>Hex-head drilling screw 6,3 x 25,4 mm</i>  26	365424	<i>Roof beam bracket</i>  SAL5	364305
<i>Ground fixing bracket</i>  7	364580	<i>T-shaped roof profile seal</i>  30	362808	<i>Front window support</i>  SAL6	
<i>Nylon dowel 8x40</i>  8	365580				
<i>Countersunk screw M5x60</i>  9	365548	<i>Pan head drilling screw 4,2x13mm</i>  43	365426		

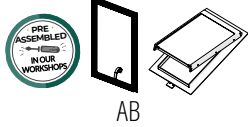
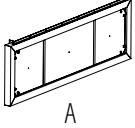
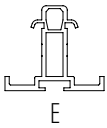
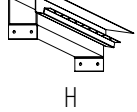
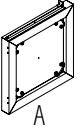
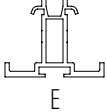
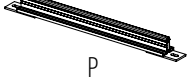
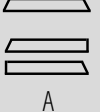
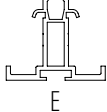
LIST OF PROFILES

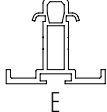
The letter on the instructions enables the part to be identified in the event of an exchange between you and customer service.

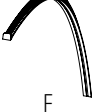
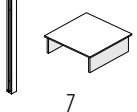
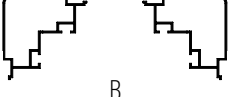
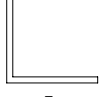
Part identification

Part detail	Dimensions	Part detail	Dimensions	Part detail	Dimensions	Part detail	Dimensions
<p>Baseplate - Front and rear side</p> 	<p>Glasshouse L. 3.80 m: L. 3720 mm Glasshouse L. 4.55 m: L. 4471 mm Glasshouse L. 5.30 m: L. 5222 mm Glasshouse L. 6.05 m: L. 6043 mm</p>	<p>Front beam</p> 	<p>Glasshouse L. 3.80 m: L. 3724 mm Glasshouse L. 4.55 m: L. 4475 mm Glasshouse L. 5.30 m: L. 5226 mm Glasshouse L. 6.05 m: L. 5977 mm</p>	<p>Curved exterior roof profile</p> 	<p>L. 3117 mm</p>	<p>Roof and wall window</p> 	<p>Wall window: L. 0.35 x H. 0.63 m (front) L. 0.35 x H. 1.00 m (rear)</p> <p>Roof window : L. 0.40 x H. 0.60 m</p>
<p>Baseplate - Gable side without door</p> 	<p>L. 2706 mm</p>	<p>T-shaped front profile</p> 	<p>Ridge height 2.70 m Base H. 40 cm: L. 1120 mm Base H. 87 cm: L. 650 mm</p> <p>Ridge height 3.10 m Base H. 40 cm: L. 1513 mm Base H. 87 cm: L. 1043 mm</p>	<p>Roof ridge</p> 	<p>Glasshouse L. 3.80 m: 3800 mm Glasshouse L. 4.55 m: 4551 mm Glasshouse L. 5.30 m: 5302 mm Glasshouse L. 6.05 m: 6053 mm</p>		
<p>Baseplate - Gable side with door</p> 	<p>Wall side: L. 788 mm Front side: L. 826 mm</p>	<p>T-shaped rear profile</p> 	<p>Ridge height 2.70 m Base H. 40 cm: L. 2159 mm Base H. 87 cm: L. 1689 mm</p> <p>Ridge height 3.10 m Base H. 40 cm: L. 2552 mm Base H. 87 cm: L. 2082 mm</p>	<p>Window stopper profile</p> 	<p>Only for H. 40 cm base and the models with a ridge height of 3.10 m: L. 358 mm</p>		
<p>Aluminium coping - Front and rear side</p> 	<p>Glasshouse L. 3.80 m: L. 3907 mm Glasshouse L. 4.55 m: L. 3889 + L. 885 mm Glasshouse L. 5.30 m: L. 3889 + L. 1637 mm Glasshouse L. 6.05 m: L. 3889 + L. 2388 mm</p>	<p>T-shaped gable profile</p> 	<p>Ridge height 2.70 m L. 1435 mm / L. 965 mm L. 1680 mm / L. 1210 mm L. 1865 mm / L. 1395 mm L. 2010 mm / L. 1540 mm L. 2115 mm / L. 1645 mm L. 2182 mm / L. 1712 mm L. 2193 mm / L. 1723 mm Above door: L. 270 & 415 mm</p> <p>Base H. 40 cm Base H. 87 cm</p>	<p>Door frame cover</p> 	<p>Base H. 40 cm: L. 1600 mm</p> <p>Base H. 87 cm: L. 1130 mm</p>		
<p>Aluminium coping - Gable side without door</p> 	<p>L. 2914 mm</p>	<p>T-shaped gable profile</p> 	<p>Ridge height 3.10 m L. 1818 mm / L. 1348 mm L. 1865 mm / L. 1395 mm L. 2010 mm / L. 1540 mm L. 2063 mm / L. 1593 mm L. 2498 mm / L. 2028 mm L. 2565 mm / L. 2095 mm L. 2576 mm / L. 2106 mm Above door: L. 653 & 798 mm</p> <p>Base H. 40 cm Base H. 87 cm</p>	<p>Roof ridge coping</p> 	<p>Not applicable</p>		
<p>Aluminium coping - Gable side with door</p> 	<p>Wall side: L. 882 mm Front side: L. 932 mm</p>	<p>Curved interior roof profile</p> 	<p>L. 3117 mm</p>	<p>Pole + cap</p> 	<p>Ridge height 2.70 m Baseplate: L. 2666 mm Low wall H. 40 cm: L. 2266 mm Low wall H. 87 cm: L. 1796 mm</p> <p>Ridge height 3.10 m Baseplate: L. 3049 mm Low wall H. 40 cm: L. 2649 mm Low wall H. 87 cm: L. 2179 mm</p>		
<p>Wall corner profile (Left and Right)</p> 	<p>Ridge height 2.70 m Base H. 40 cm: L. 1152 mm Base H. 87 cm: L. 682 mm</p> <p>Ridge height 3.10 m Base H. 40 cm: L. 1546 mm Base H. 87 cm: L. 1076 mm</p>	<p>Roof beam</p> 	<p>Glasshouse L. 3,80 m: L. 3720 mm Glasshouse L. 4,55 m: L. 4471 mm Glasshouse L. 5,30 m: L. 5222 mm Glasshouse L. 6,05 m: L. 5973 mm</p>	<p>Door</p> 	<p>Single door : L. 1.00 x H. 1.95 m</p>		

Only for the models on low wall

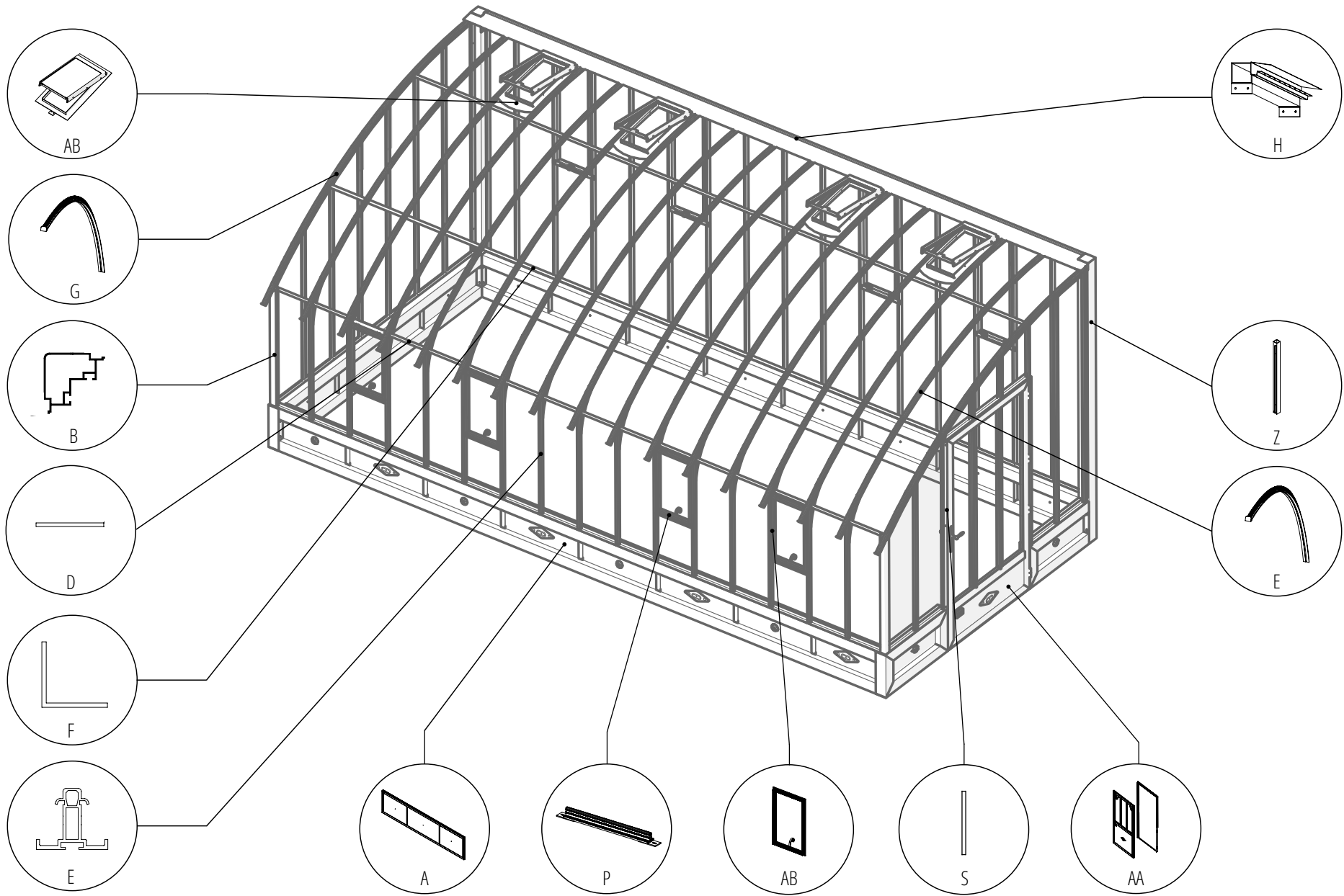

MASONRY PLAN FOR THE LOW WALL

35 mm overhang of the aluminium coping, which allows the installation of cladding < 30 mm

Please note to reproduce the side with door on the opposite side if you have chosen an additional door.

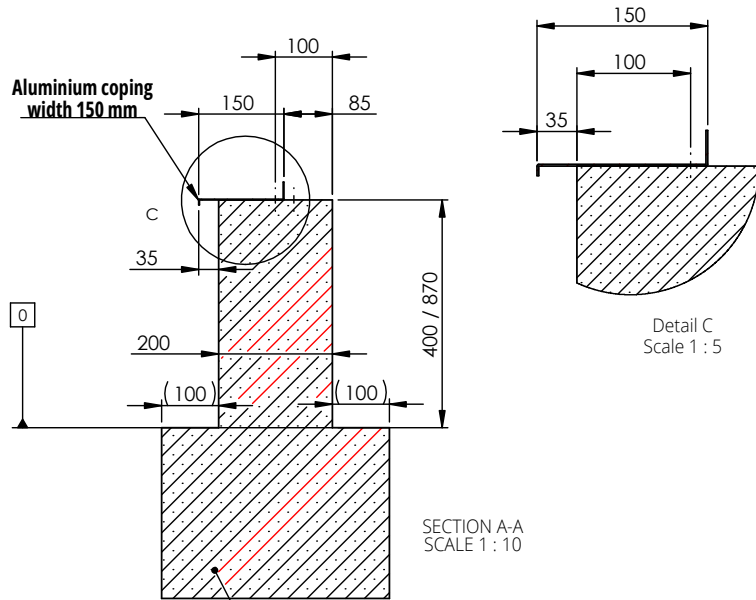

Concrete foundation: size depending on the type of ground. We recommend that you contact a local builder for the necessary size.

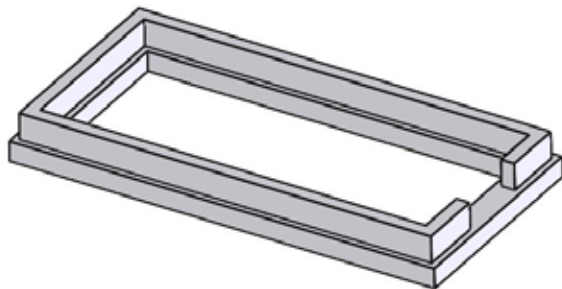

View from above

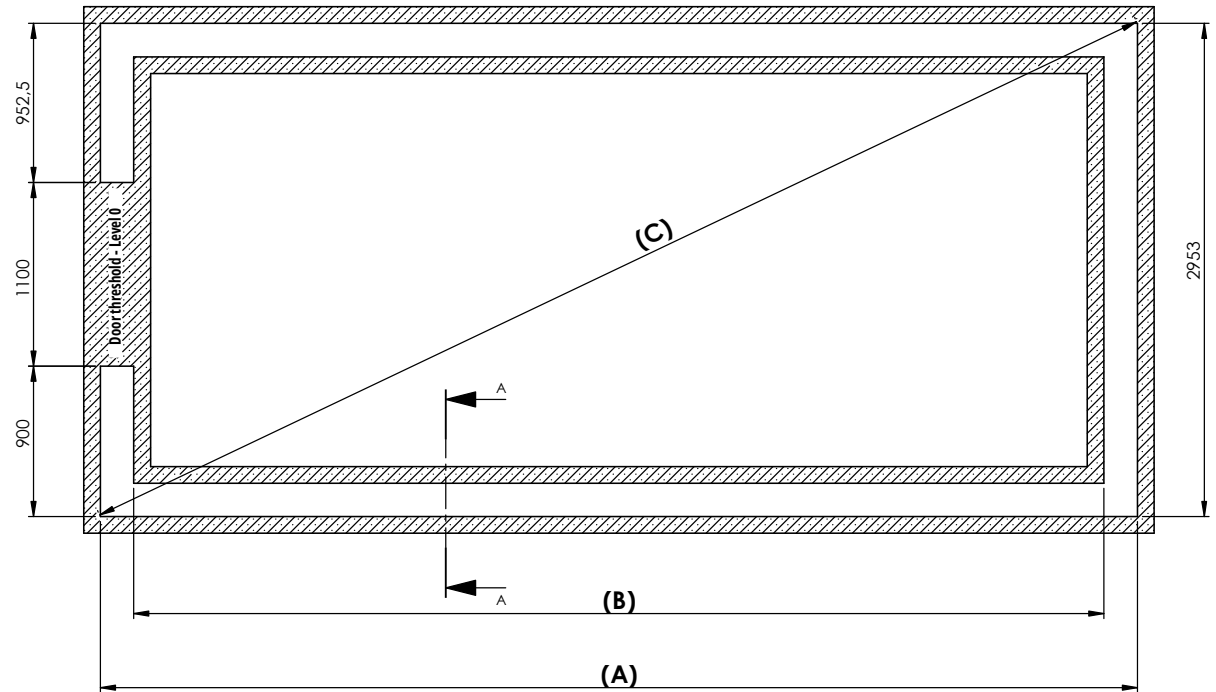

Glasshouse length	3.80 m	4.55 m	5.30 m	6.05 m
Measure A (mm)	3954	4705	5456	6207
Measure B (mm)	3554	4305	5056	5807
Measure C (mm)	4935	5555	6204	6874

ASSEMBLING THE POLES AND ROOF RIDGE ON THE GROUND

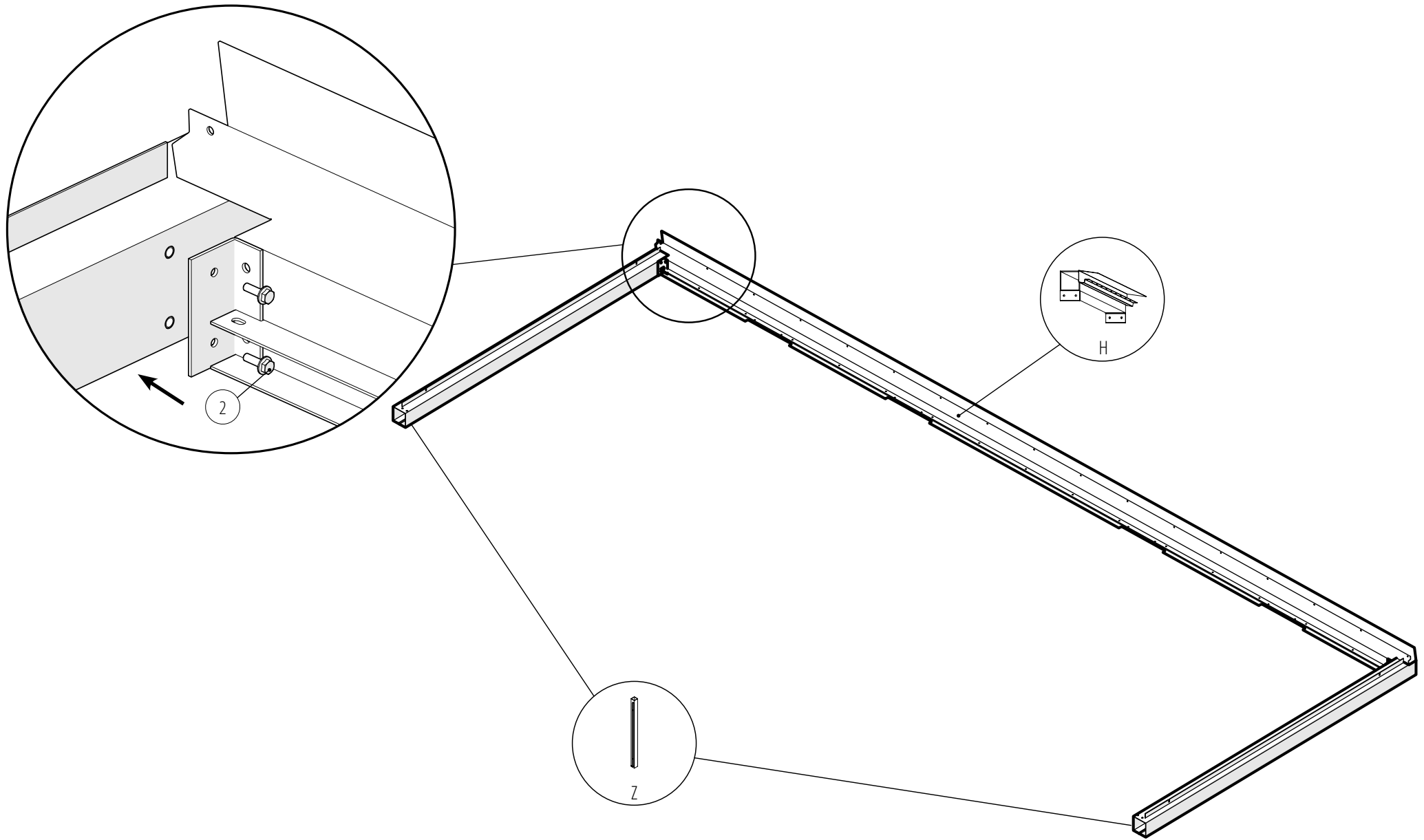

POSITIONING AND FIXING THE ALUMINIUM COPING - GLASSHOUSE ON LOW WALL

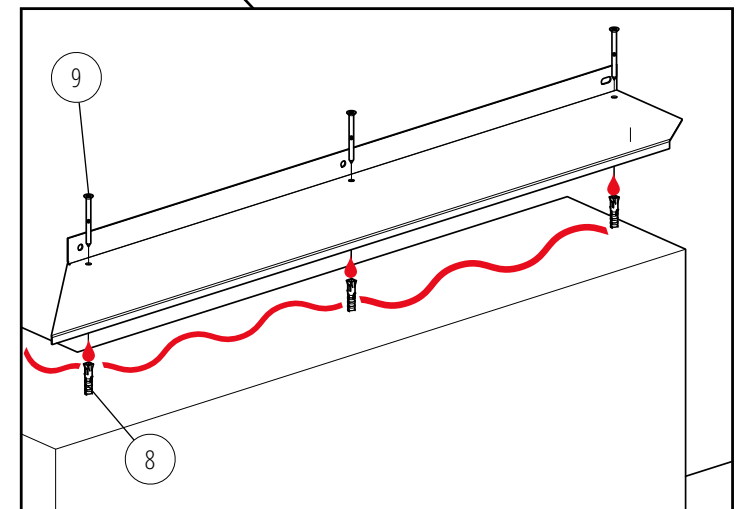
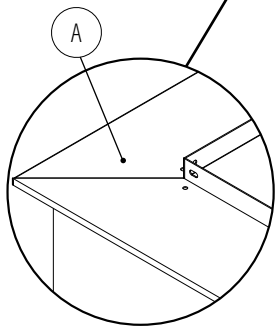
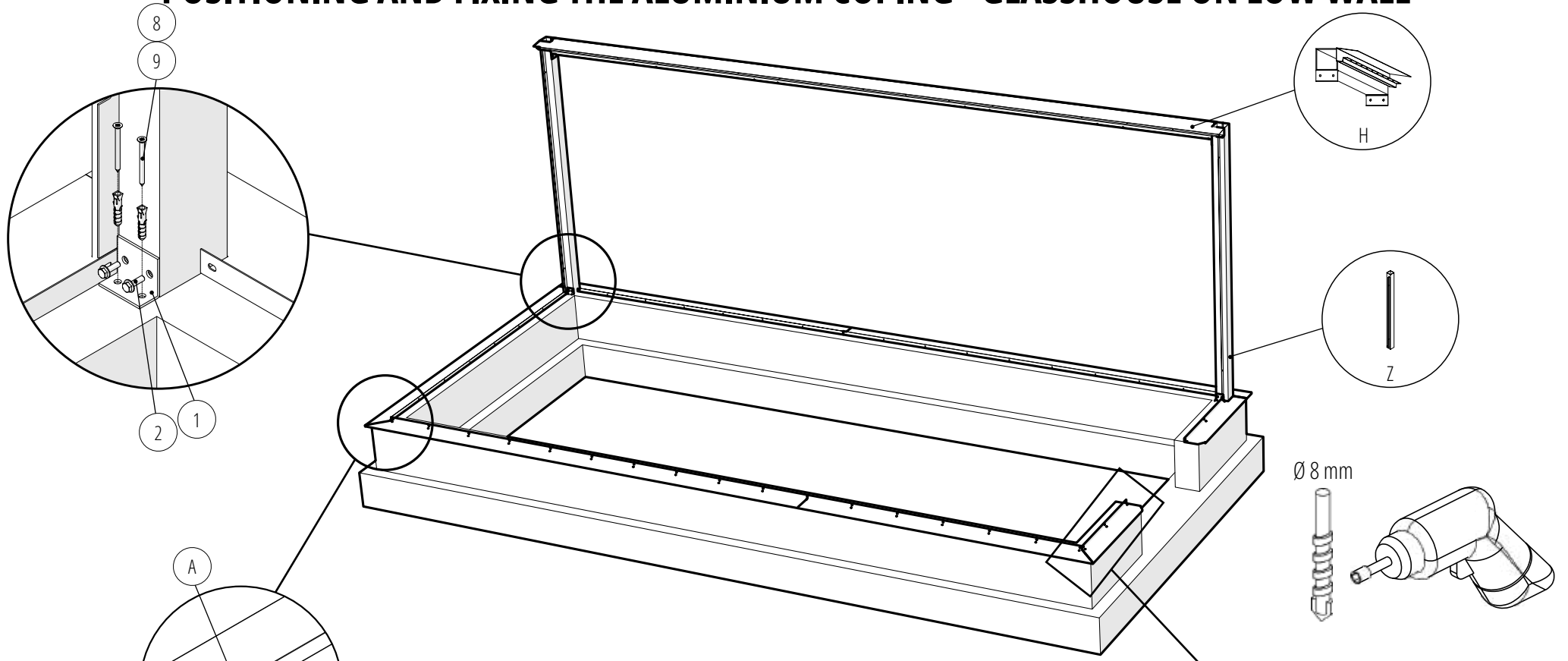

GABLE PROFILE (E)

Ridge height	2.70 m	3.10 m
Base H. 40 cm	L. 2193 mm	L. 2576 mm
Base H. 87 cm	L. 1723 mm	L. 2106 mm

POSITIONING AND FIXING THE ALUMINIUM COPING AND DOOR FRAME - GLASSHOUSE ON LOW WALL

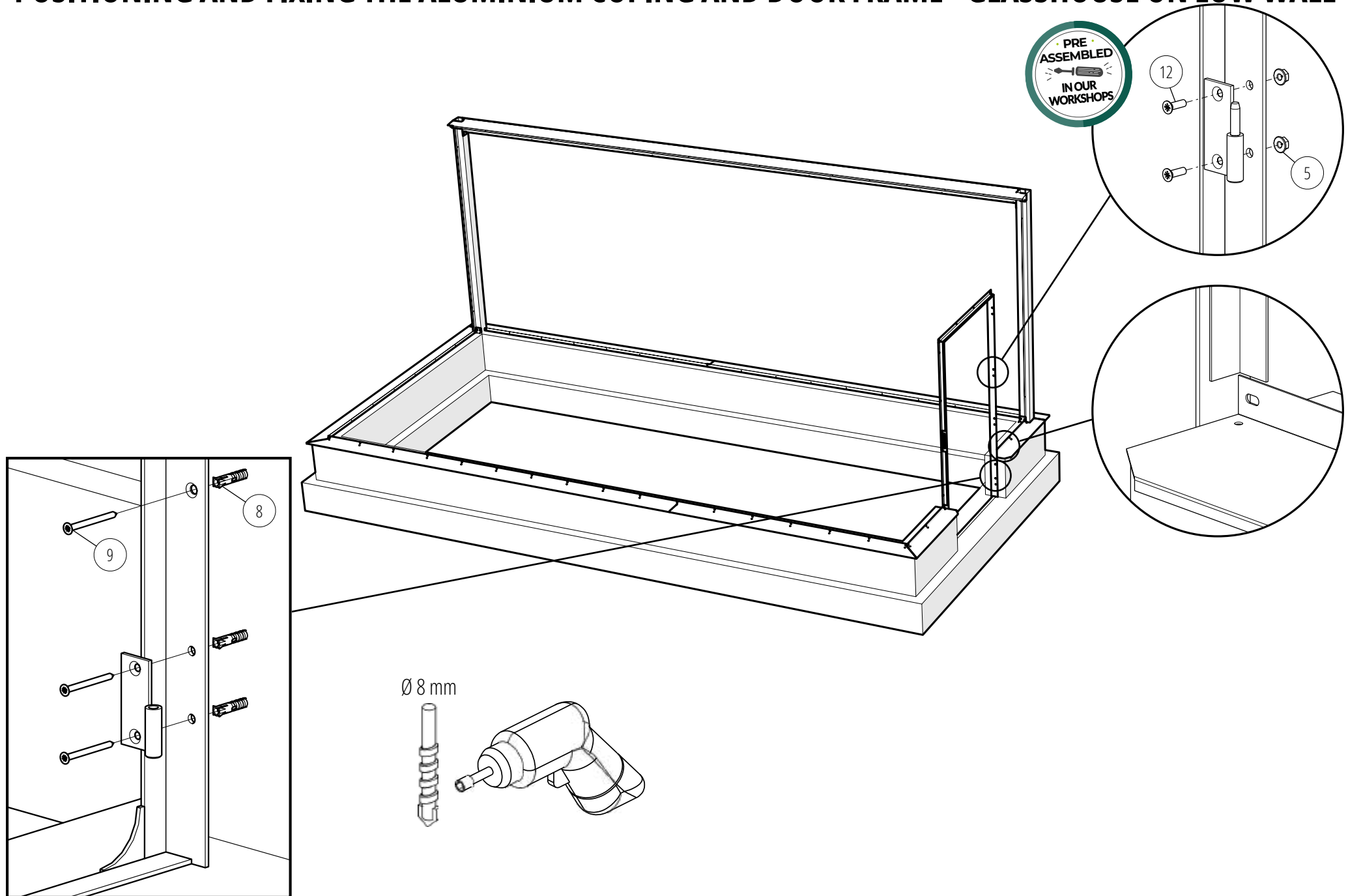

MASONRY PLAN FOR THE CONCRETE BLOCKS

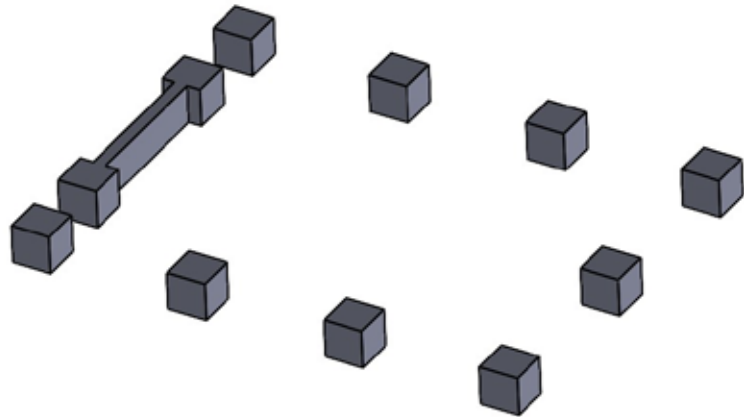
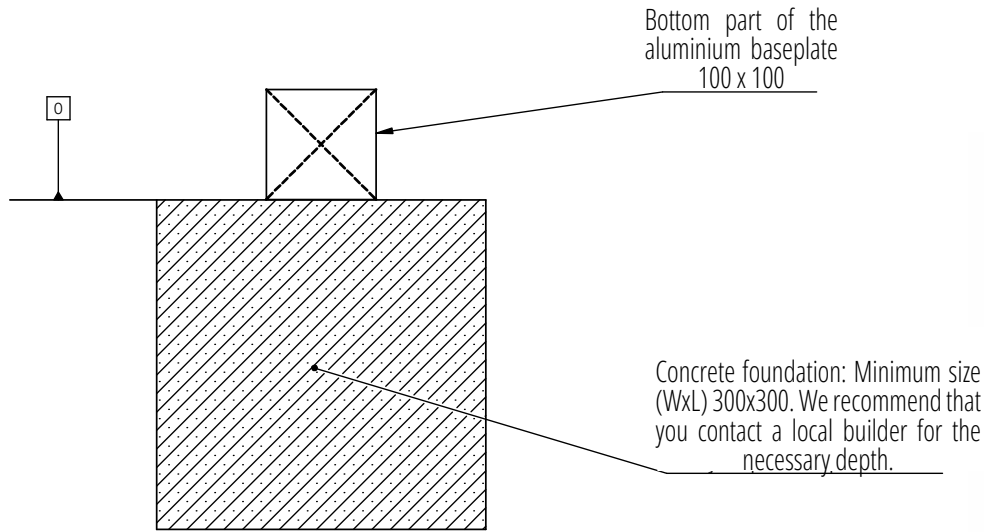

Please note to reproduce the side with door on the opposite side if you have chosen an additional door.

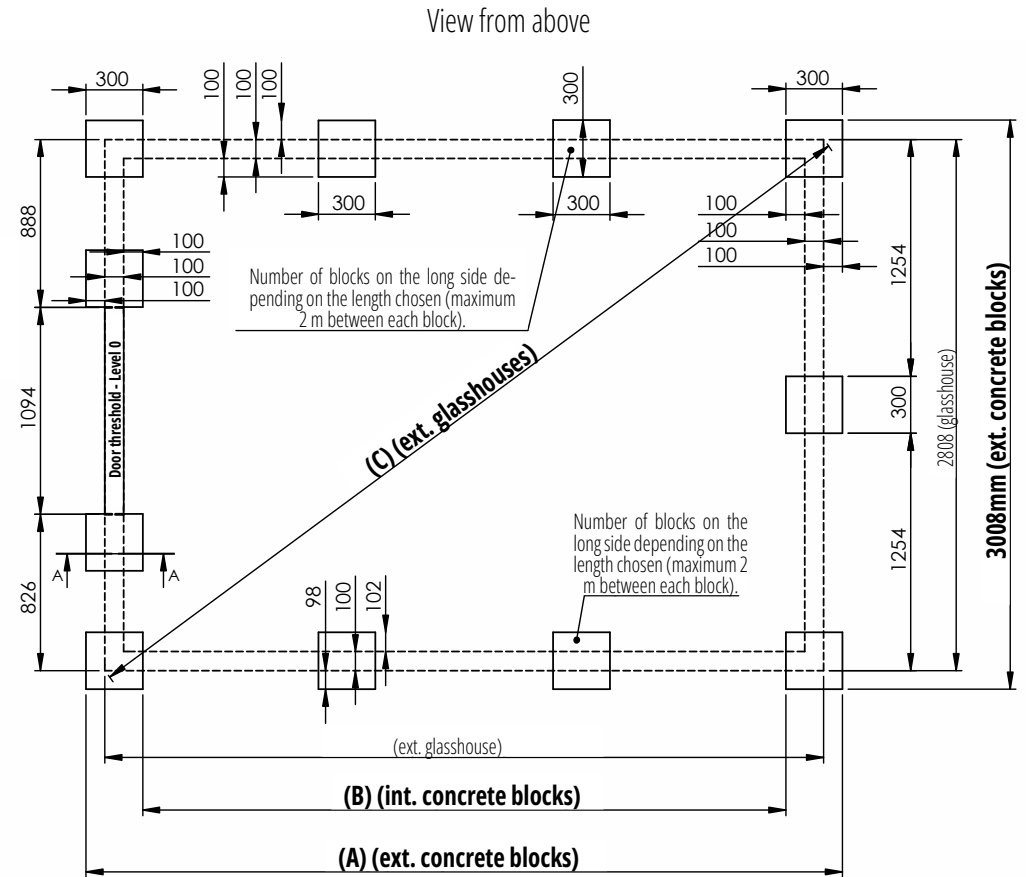

Glasshouse length	3.80 m	4.55 m	5.30 m	6.05 m
Measure A (mm)	4000	4751	5502	6253
Measure B (mm)	3400	4151	4902	5653
Measure C (mm)	4724	5347	5998	6670

ASSEMBLING THE POLES AND ROOF RIDGE ON THE GROUND

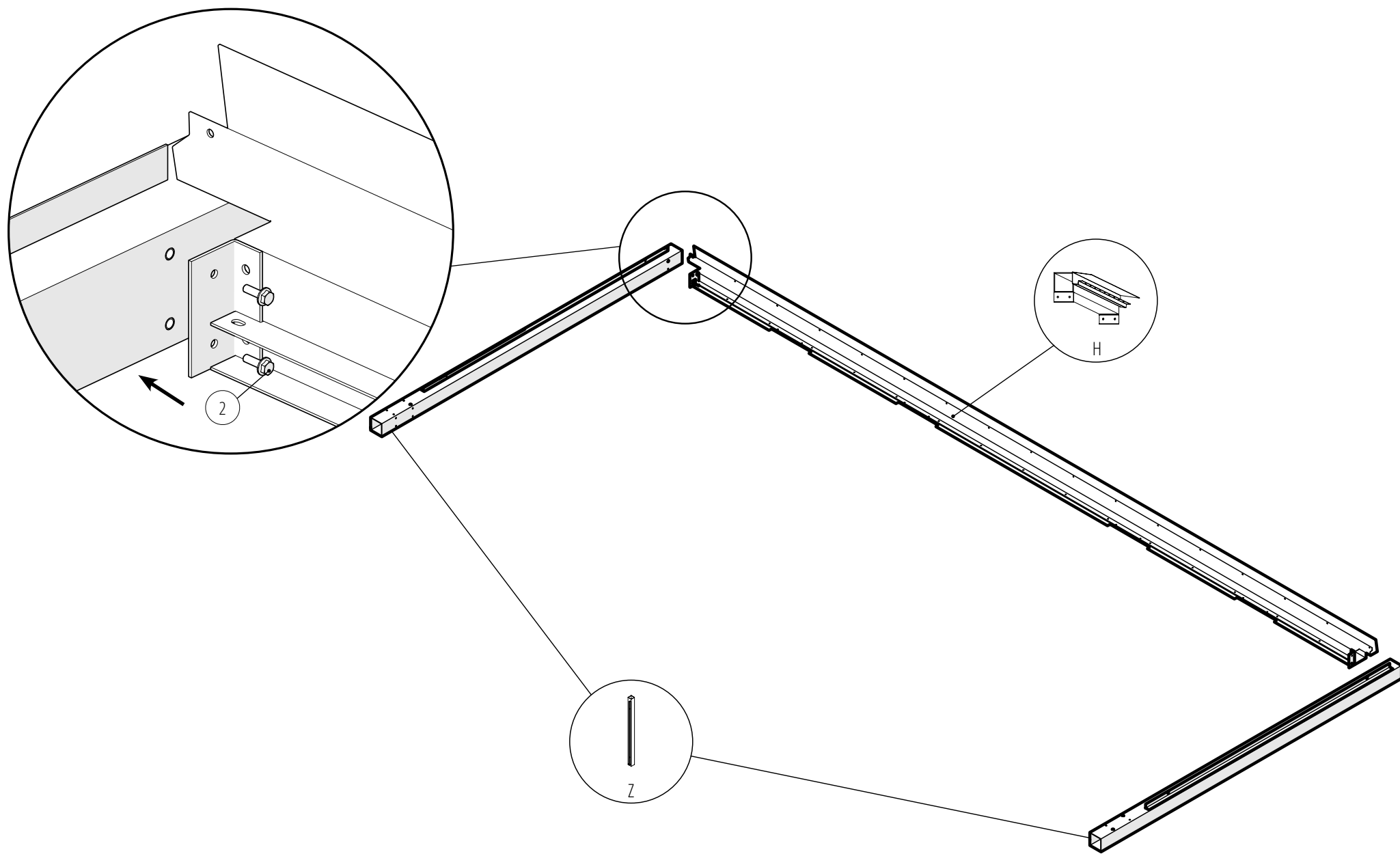

ASSEMBLING THE ALUMINIUM BASEPLATE, THE DOOR FRAME AND THE POLES WITH THE RIDGE

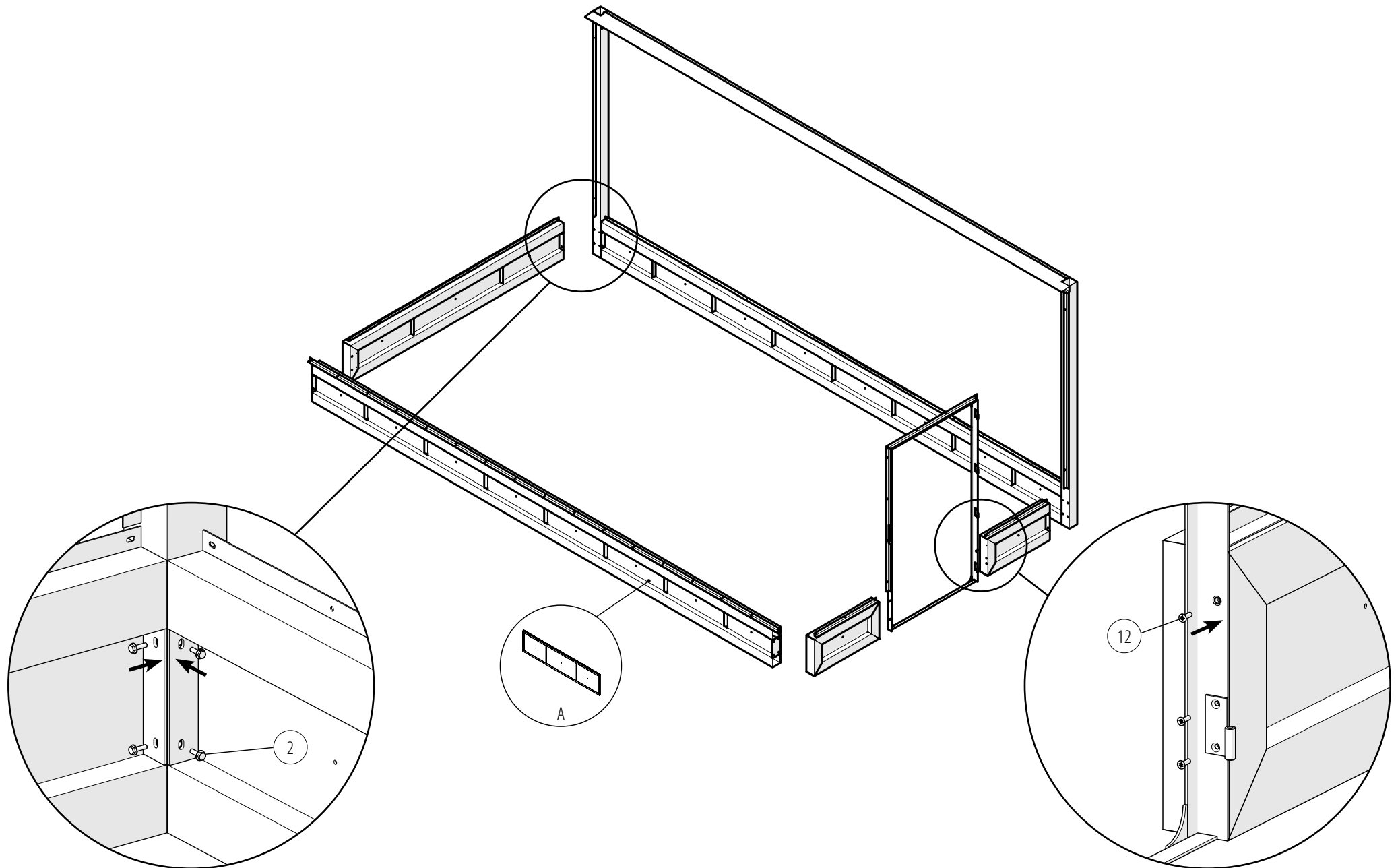

FIXING THE BASEPLATE TO THE GROUND

Fixing the brackets to the ground and to the lower part of the aluminium baseplate.

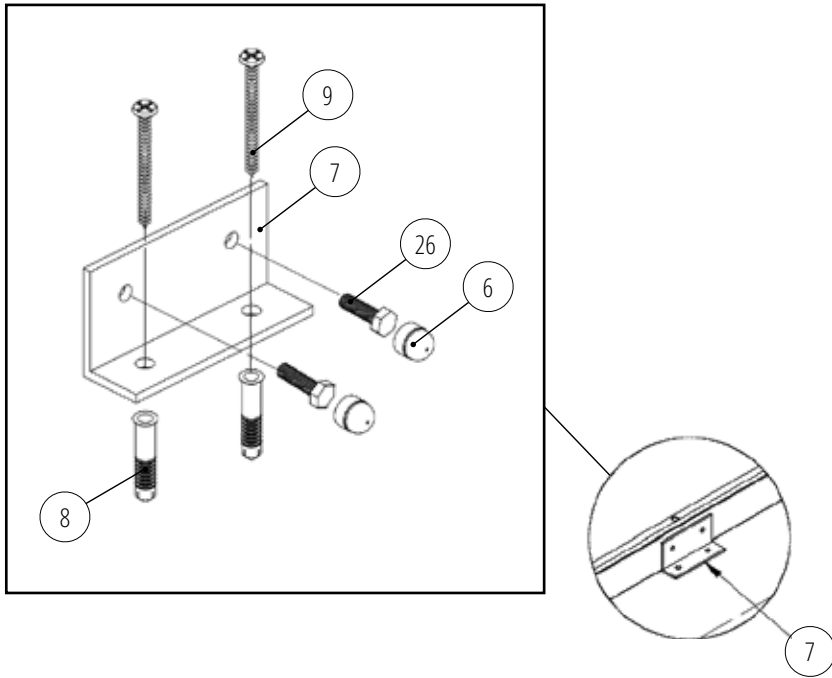

It is important that the 2 diagonales of the glasshouse are equal to obtain the necessary squareness.

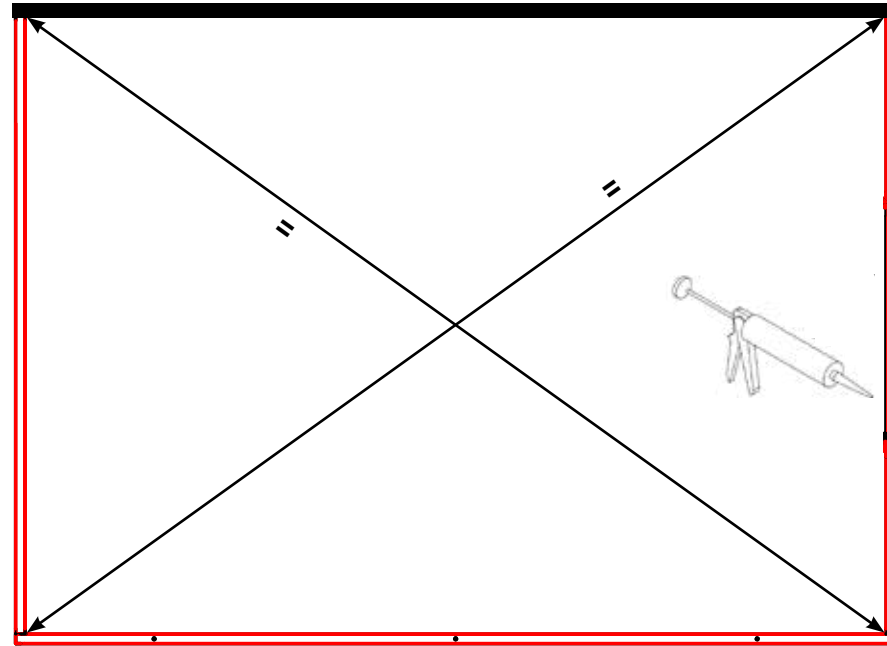

After fixing the brackets, silicone the lower part of the inside of the glasshouse.

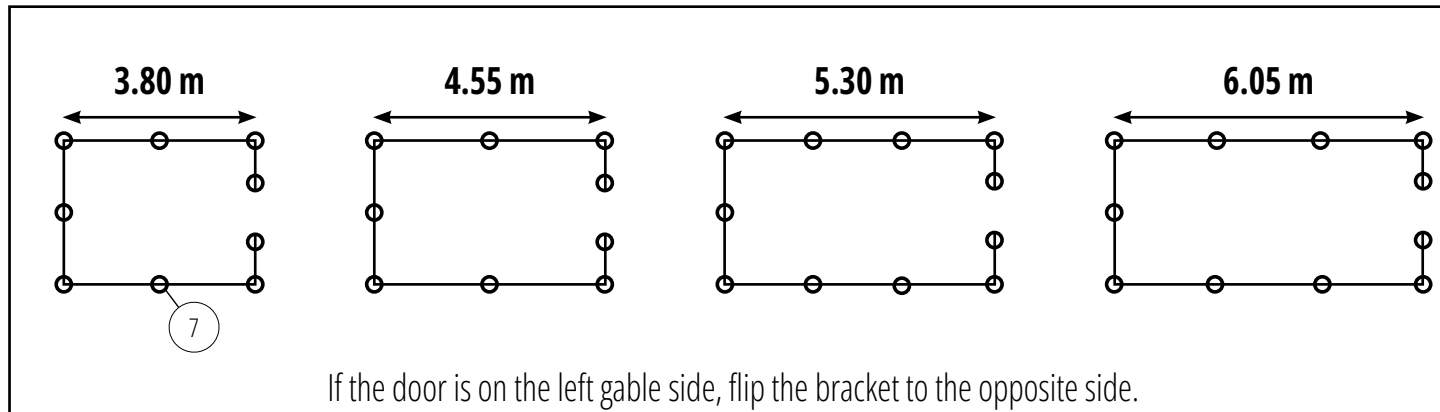

If the door is on the left gable side, flip the bracket to the opposite side.



**THE FOLLOWING ASSEMBLY STEPS APPLY FOR
BOTH GLASSHOUSES ON A LOW WALL AND ON AN
ALUMINIUM BASEPLATE**

INSTALLING THE SEAL ON THE ROOF PROFILES

To simplify installation, we recommend that you position the seal on the roof profiles before installing them on the glasshouse (reminder on the relevant pages provided). We recommend that you immerse your hands in soapy water to make fitting easier. Lay the seal along the roof profiles and trim off any excess with a pair of scissors.

Please note that the seal only needs to be positioned on the roof profiles and not on the wall profiles.

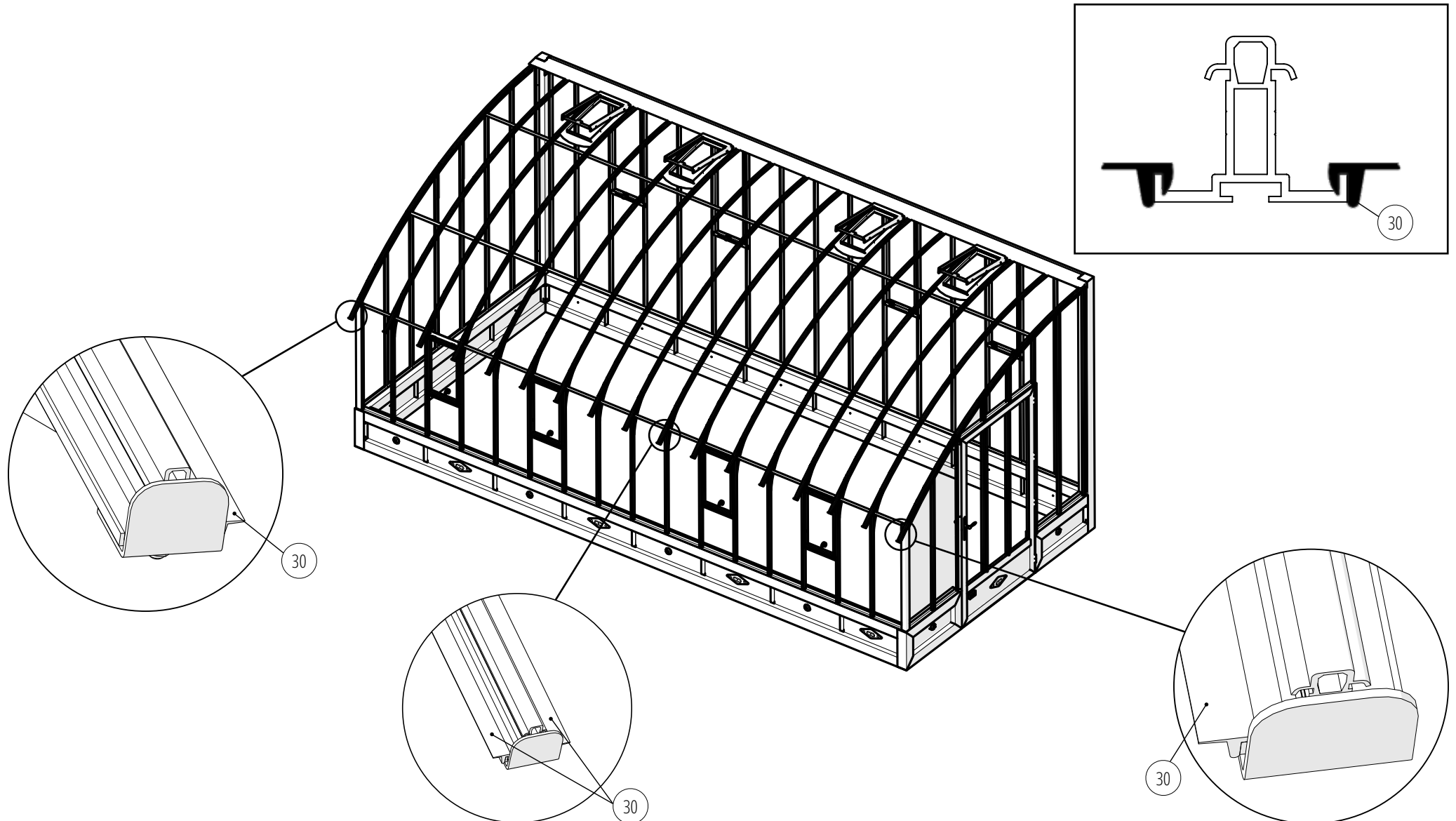

INSTALLING THE WALL CORNER PROFILES

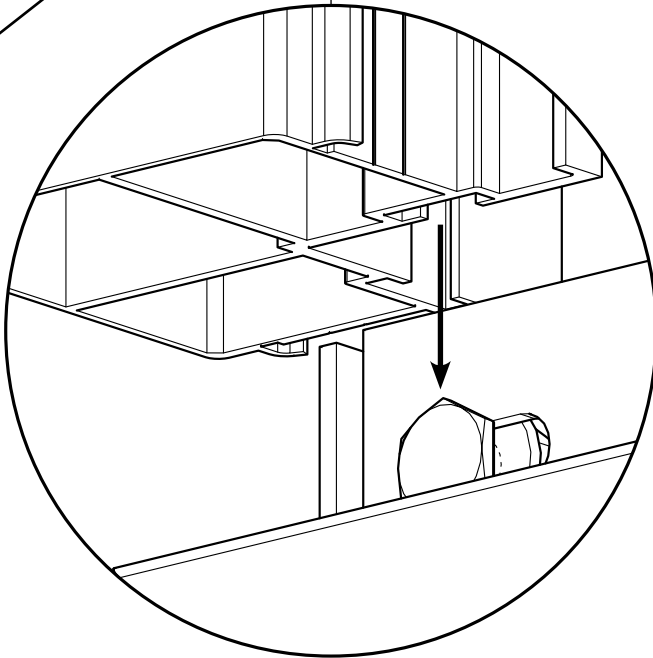
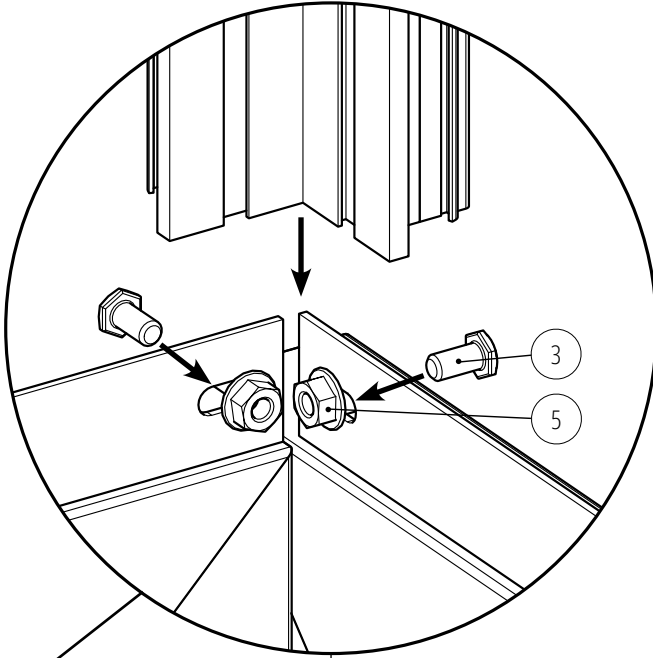
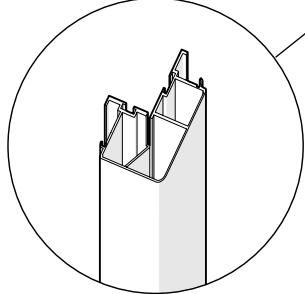
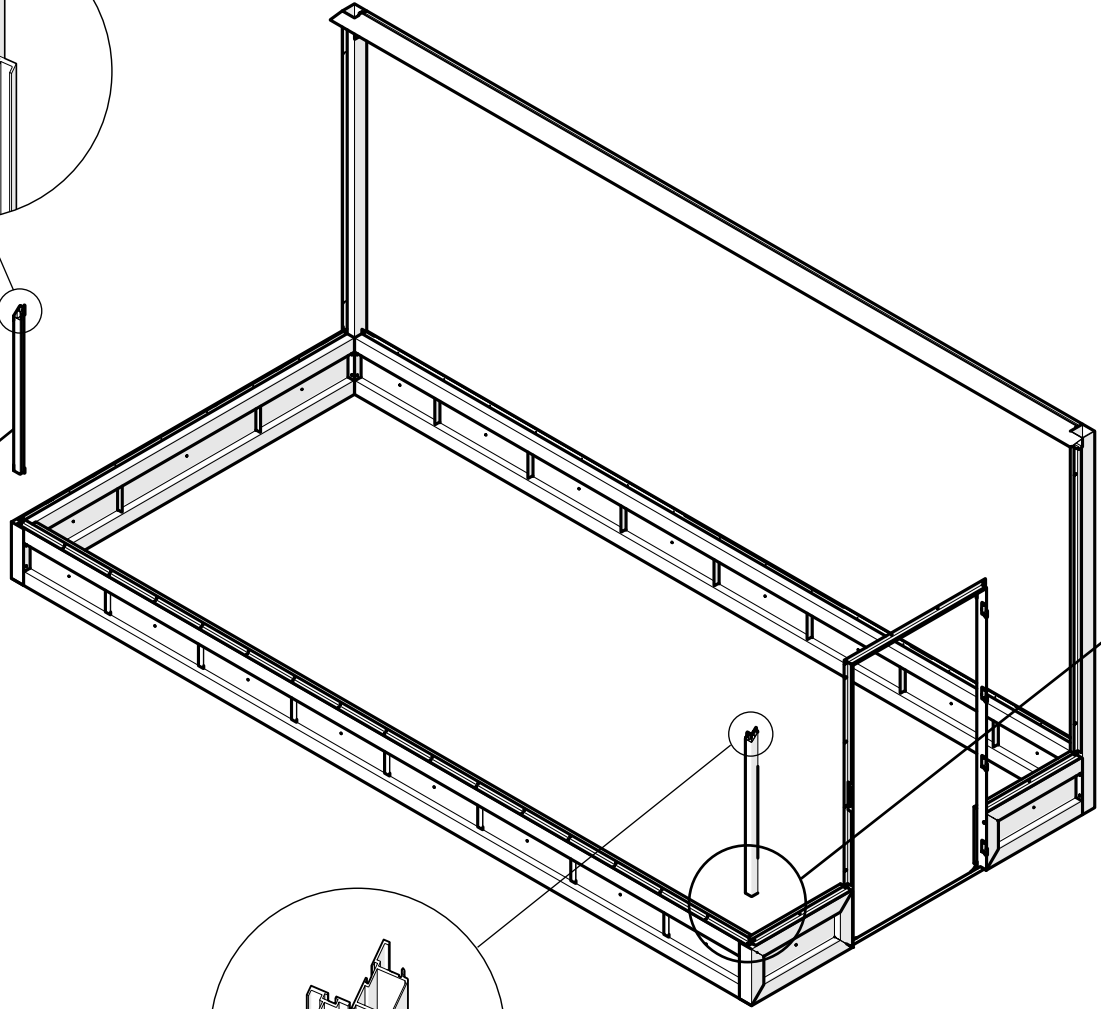
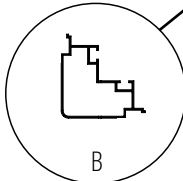
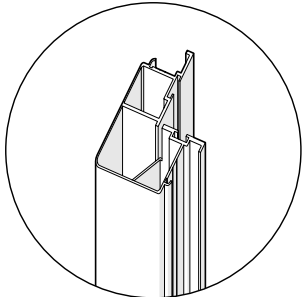

INSTALLING THE CURVED EXTERIOR ROOF PROFILE

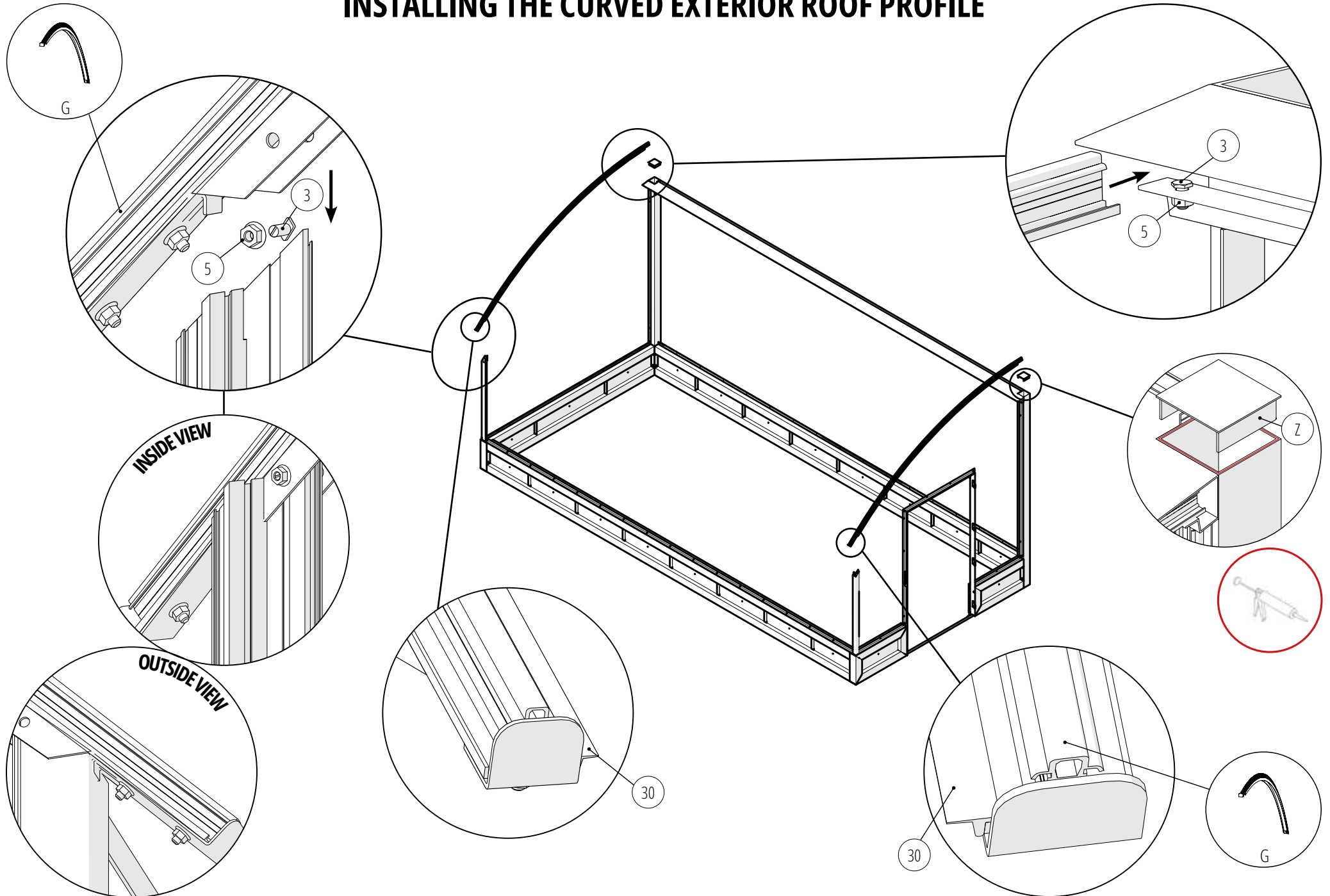

INSTALLING THE BLACK WALL AND GABLE PROFILES

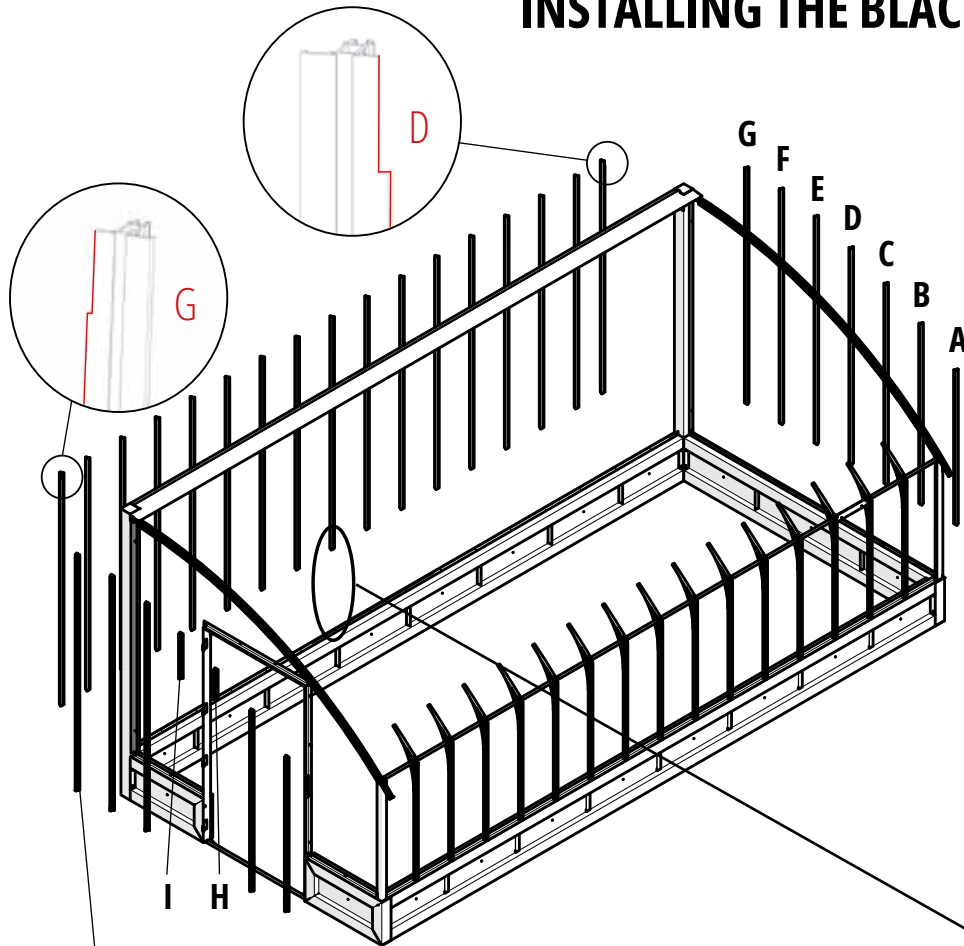

Ridge height 2.70 m							
LETTER	A	B	C	D	E	F	G
Base H. 40 cm	1435 mm	1680 mm	1865 mm	2010 mm	2115 mm	2182 mm	2193 mm
Base H. 87 cm	965 mm	1210 mm	1395 mm	1540 mm	1645 mm	1712 mm	1723 mm

Above side door	
H	I
270 mm	415 mm

Ridge height 3.10 m							
REPÈRES	A	B	C	D	E	F	G
Support H. 40 cm	1818 mm	1865 mm	2010 mm	2063 mm	2498 mm	2565 mm	2576 mm
Support H. 87 cm	1348 mm	1395 mm	1540 mm	1593 mm	2028 mm	2095 mm	2106 mm

Above side door	
H	I
653 mm	798 mm

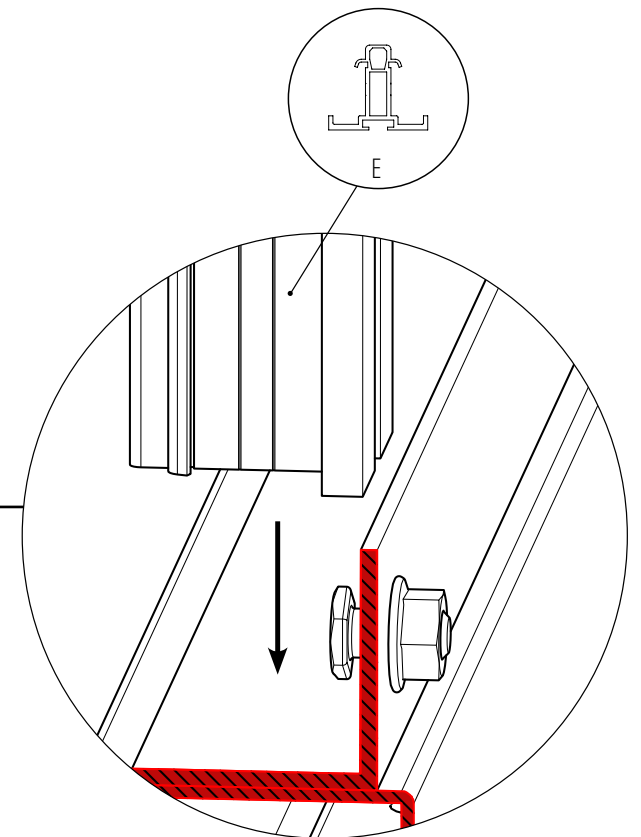
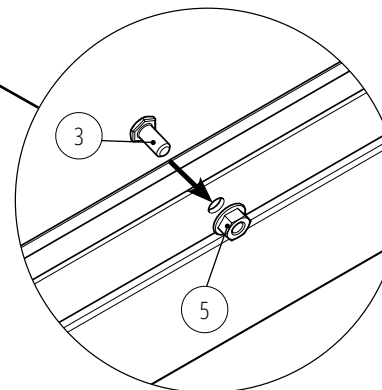
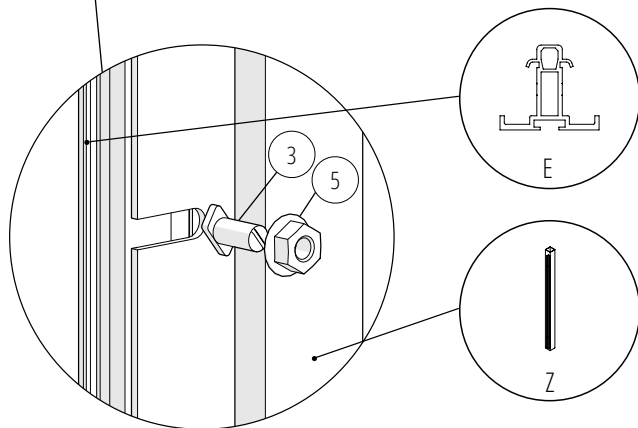

INSTALLING THE CURVED ROOF PROFILES OF THE DORMER - FIXING THE UPPER PART

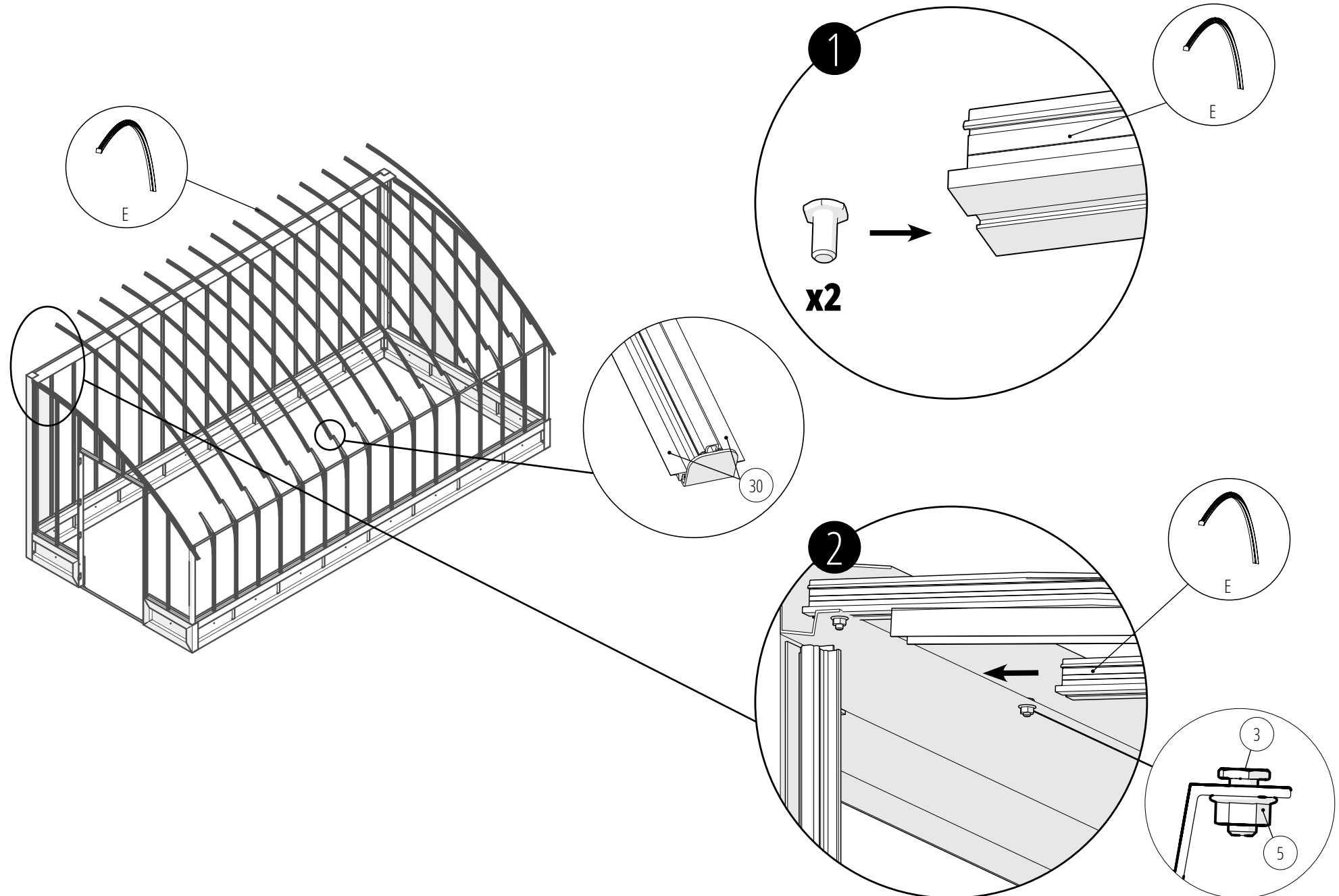

INSTALLING THE CURVED ROOF PROFILES - FIXING THE LOWER PART

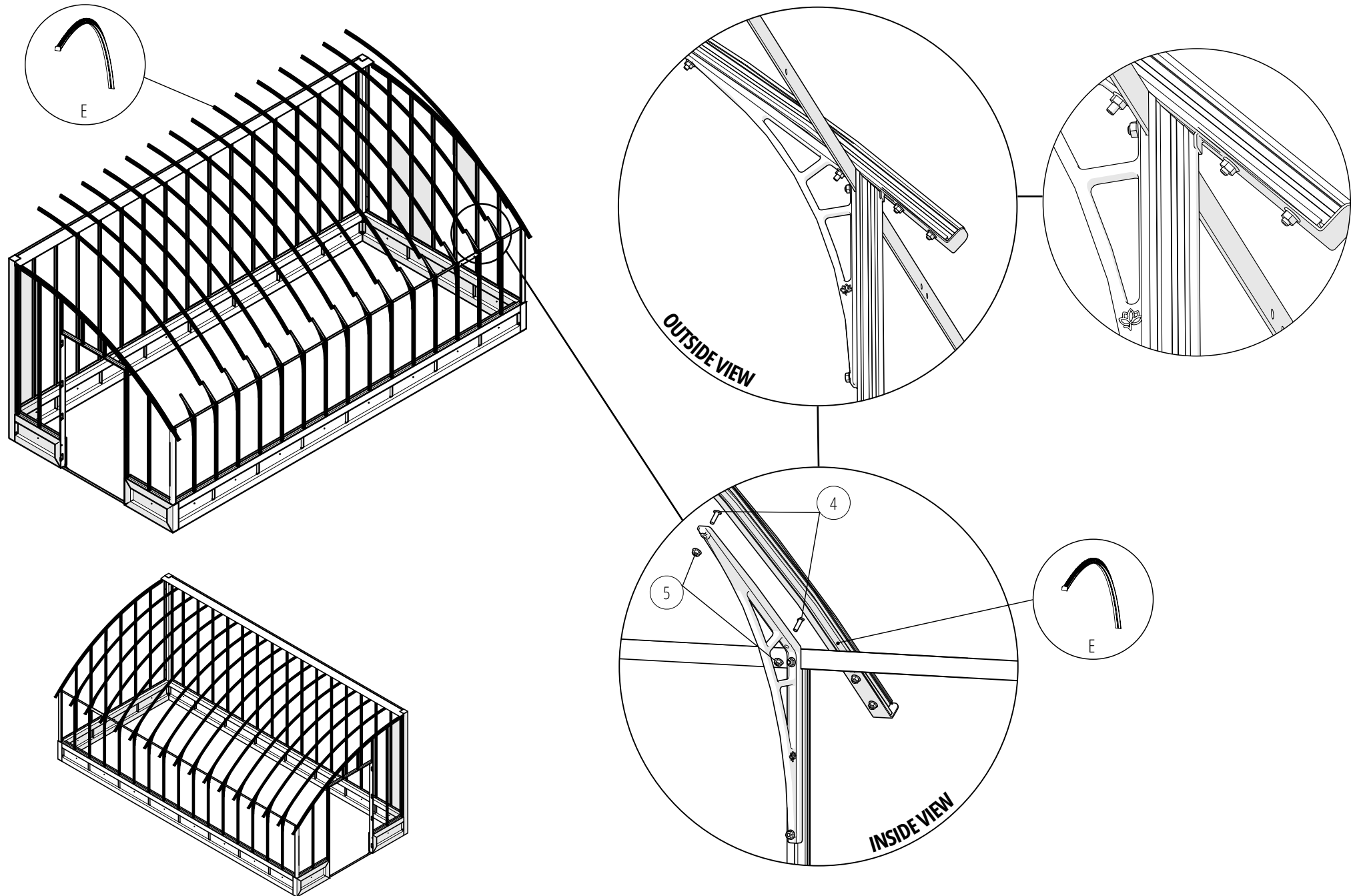

INSTALLING THE DOOR AND ROOF WINDOWS

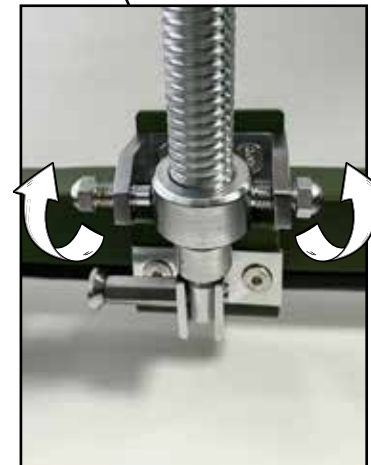
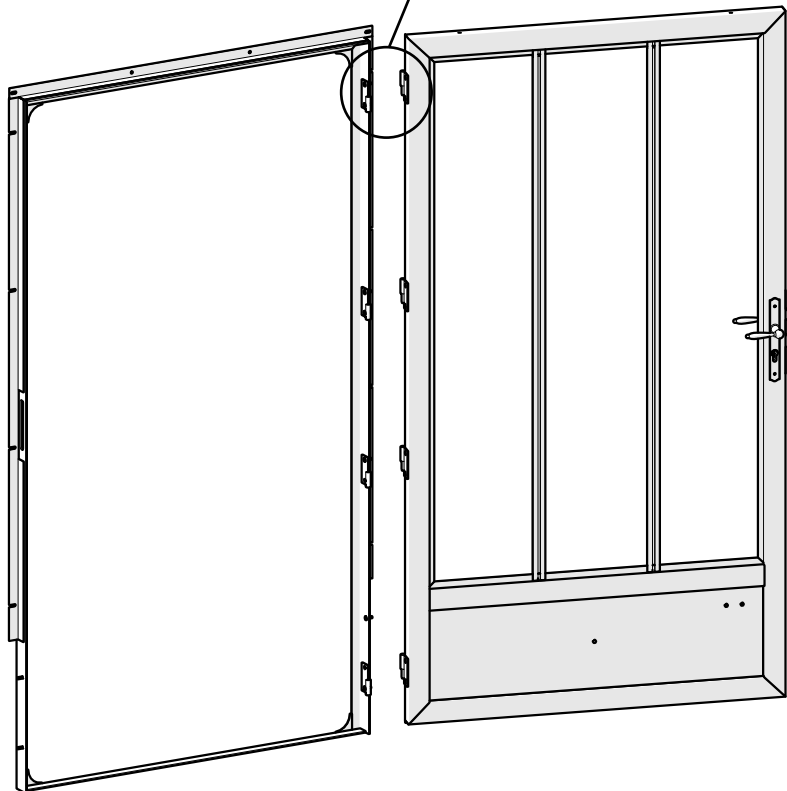
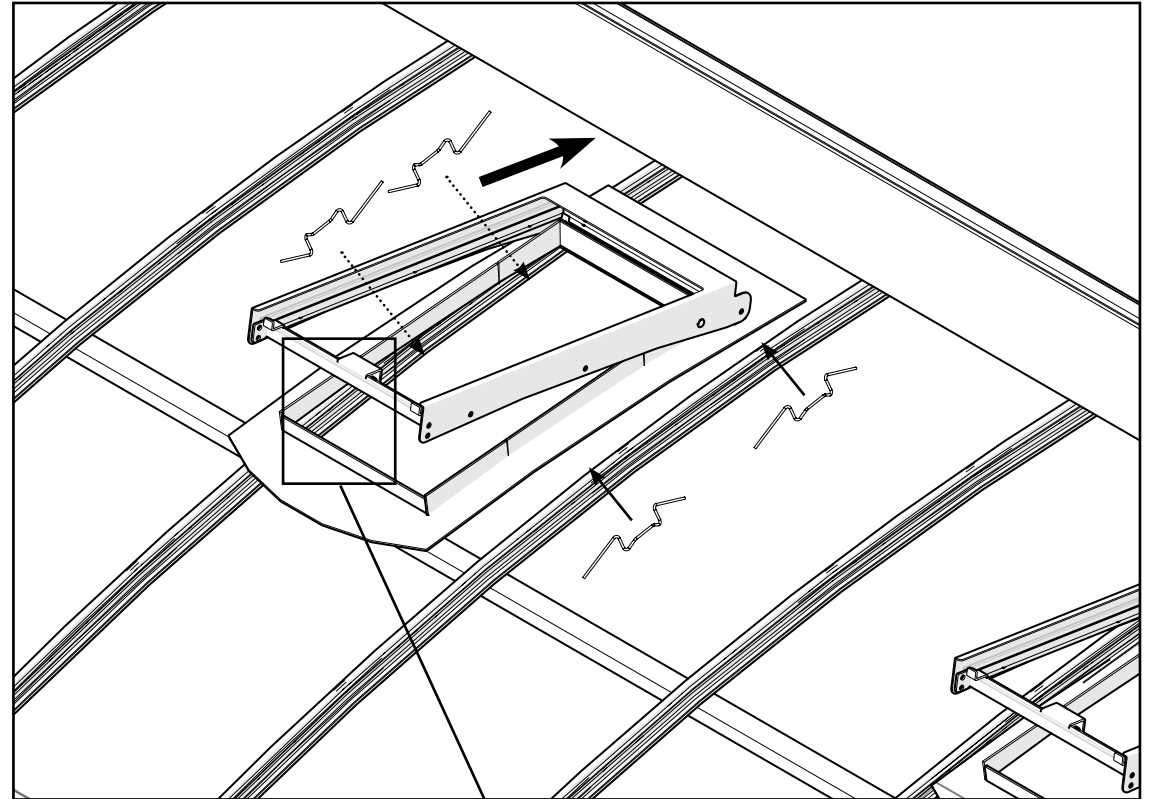
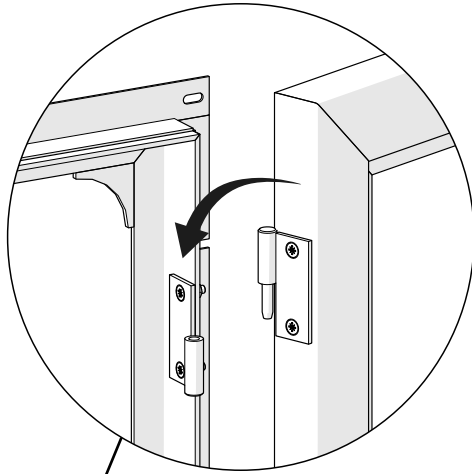

INSTALLING THE WALL WINDOWS

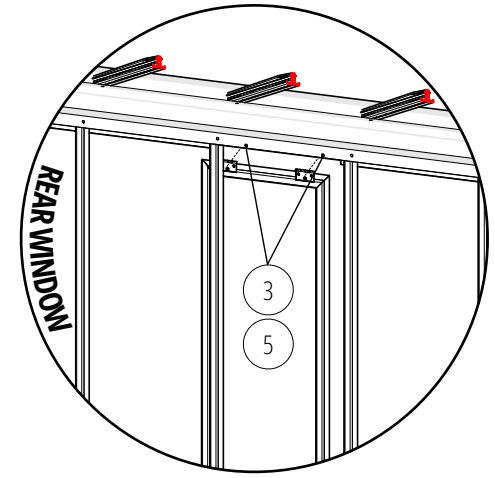
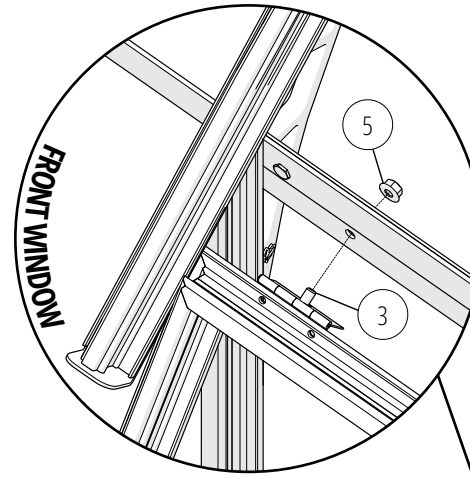
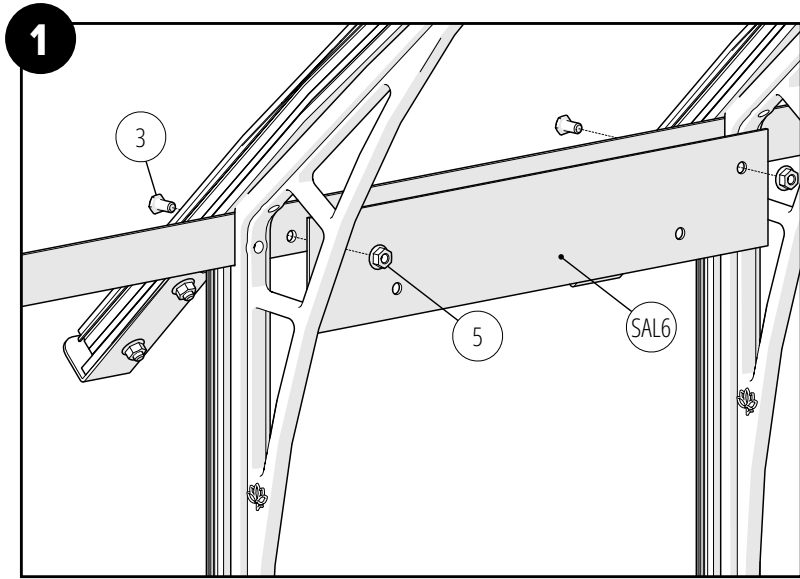

3 With a base height of 40 cm and/or a ridge height of 3.10 m, a window stopper profile (P) should be positioned as follows:

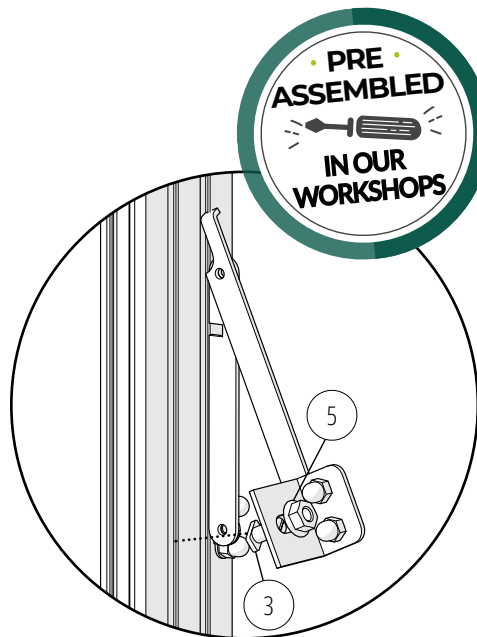
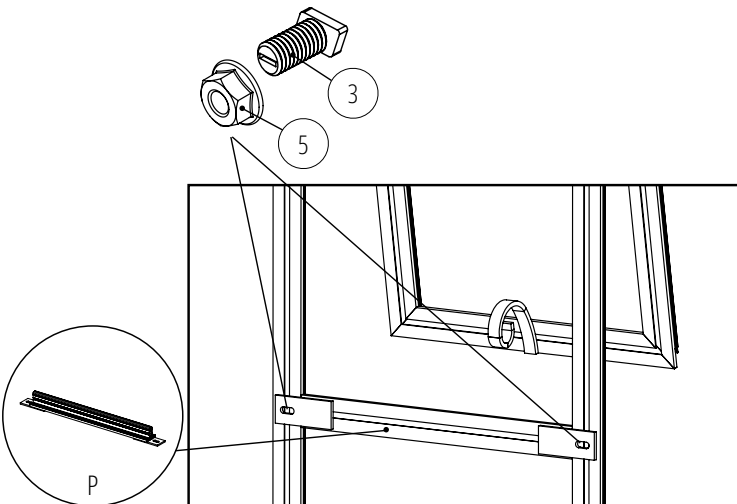

PRE
ASSEMBLED
IN OUR
WORKSHOPS

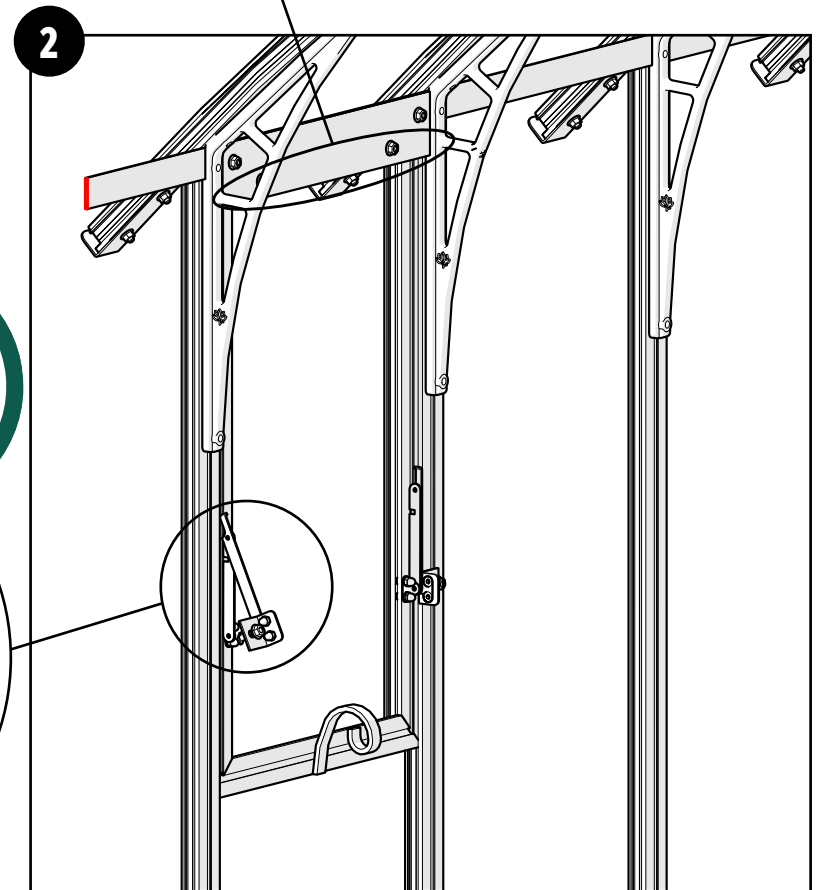

INSTALLING THE WALL AND ROOF GLAZING - RIDGE HEIGHT 2.70 M

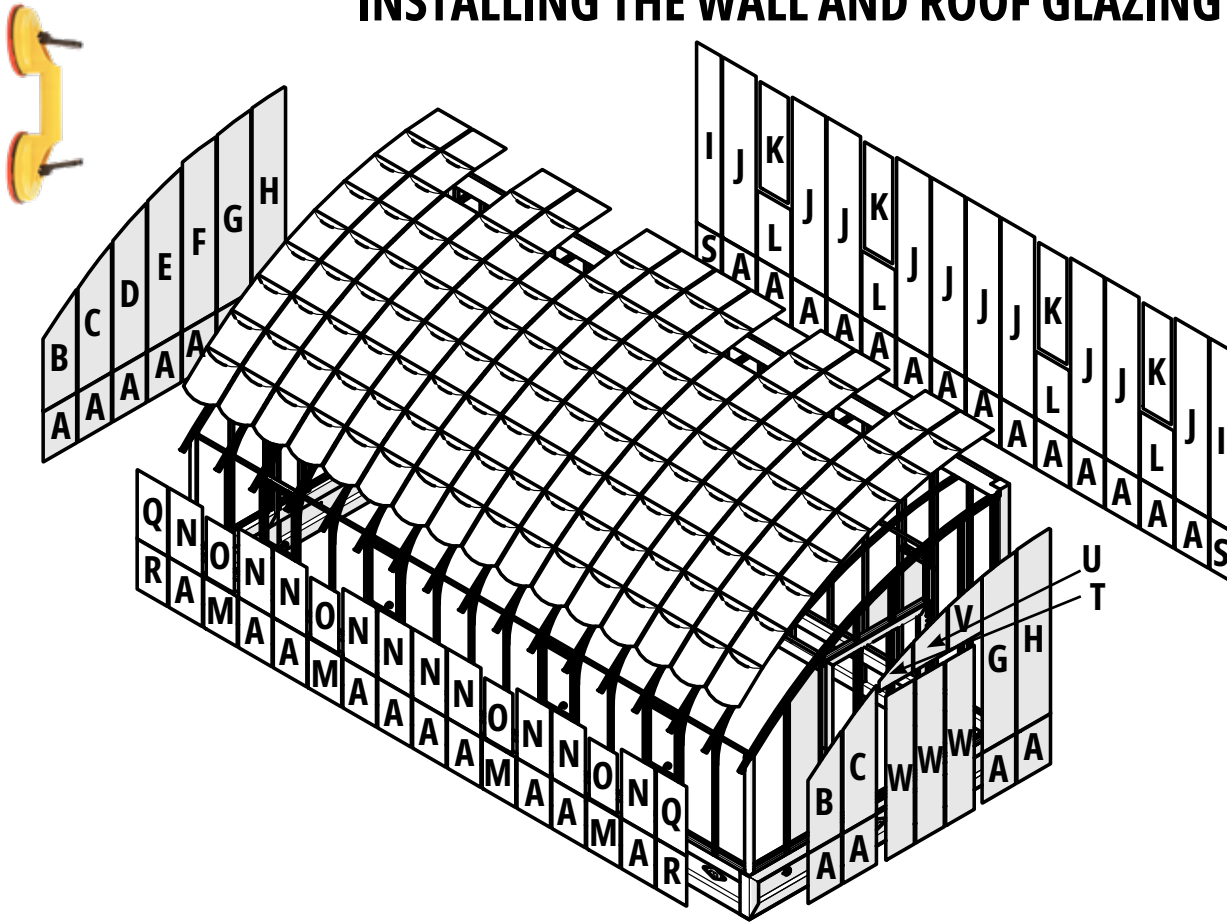

Letter	Base H. 40 cm		Base H. 87 cm	
	Size (in mm)	Number of clips	Size (in mm)	Number of clips
A	482 x 358	4	/	/
B	960 x 358	4	960 x 358	4
C	1200 x 358	4	1200 x 358	4
D	1390 x 358	4	1390 x 358	4
E	1530 x 358	4	1530 x 358	4
F	1635 x 358	6	1635 x 358	6
G	1700 x 358	6	1700 x 358	6
H	1735 x 358	6	1735 x 358	6
I	1685 x 262	6	1685 x 262	6
J	1685 x 358	6	1685 x 358	6
K	985 x 300	6	985 x 300	6
L	625 x 358	6	625 x 358	6
M	465 x 358	2	/	/
N	645 x 358	4	645 x 358	4
O	557 x 300	4	557 x 300	4
Q	645 x 324	4	645 x 324	4
R	482 x 324	2	/	/
S	482 x 262	2	/	/
T	266 x 358	2	266 x 358	2
U	410 x 358	2	410 x 358	2
V	510 x 358	2	510 x 358	2
W	1531 x 304	6	1053 x 304	6
Z	400 x 358	2	400 x 358	2

Installation of 2 S hooks (44) for the glasshouses with a 40 cm base:

Installation of the W clips (SAL1), 2 possibilities:



Roof glazing

See glass Z (see page 30)



Possibility 1



Possibility 2

INSTALLING THE WALL AND ROOF GLAZING - RIDGE HEIGHT 3.10 M

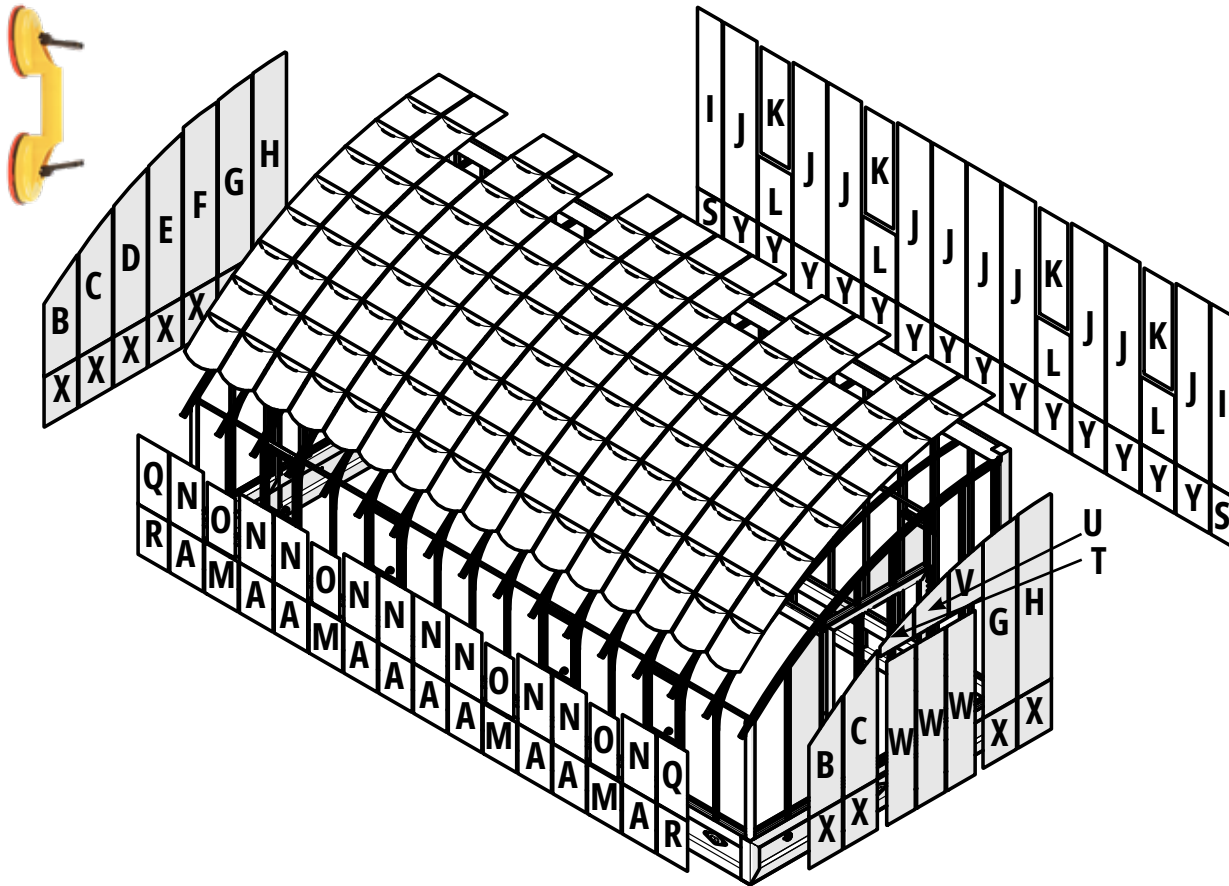

Letter	Base H. 40 cm		Base H. 87 cm	
	Size (in mm)	Number of clips	Size (in mm)	Number of clips
A	870 x 358	4	/	/
B	960 x 358	4	960 x 358	4
C	1200 x 358	4	1200 x 358	4
D	1390 x 358	4	1390 x 358	4
E	1530 x 358	4	1530 x 358	4
F	1635 x 358	6	1635 x 358	6
G	1700 x 358	6	1700 x 358	6
H	1735 x 358	6	1735 x 358	6
I	1929 x 262	6	1685 x 262	6
J	1929 x 358	6	1685 x 358	6
K	985 x 300	4	985 x 300	4
L	870 x 358	4	625 x 358	4
M	420 x 358	2	/	/
N	645 x 358	4	1030 x 358	4
O	985 x 300	4	945 x 300	4
Q	645 x 324	4	1030 x 324	6
R	870 x 324	4	/	/
S	625 x 262	4	398 x 262	2
T	645 x 358 x 457	4	645 x 358 x 457	4
U	660 x 358 x 785	4	660 x 358 x 785	4
V	890 x 358 x 795	4	890 x 358 x 795	4
W	1531 x 304	6	1053 x 304	6
X	870 x 358	4	398 x 358	2
Y	625 x 358	4	398 x 358	2
Z	400 x 358	2	400 x 358	2

Installation of 2 S hooks (44) for the glasshouses with a 40 cm base:

Installation of the W clips (SAL1), 2 possibilities:



Roof glazing

See glass Z (see page 30)



Possibility 1

Possibility 2

INSTALLING THE ROOF GLAZING - SMALL GLASS PANES (GLASS TILES)

- 1 - Place a rounded glass (Z) on the lower end of the roof, at the end of the profiles.
- 2 - Install 4 clips (SAL1) on the first glass pane (two on the right, two on the left).
- 3 - Place 2 hooks (44) on the top of the glass pane (one on the right, one on the left).
- 4 - Place the second glass, then two clips (SAL1) centered on the height of the glass then two hooks (44). Repeat this step all the way to the top of the roof.
- 5 - Install the second row, the third row, etc. in the same way, ...

Hooks on the edges of the glass

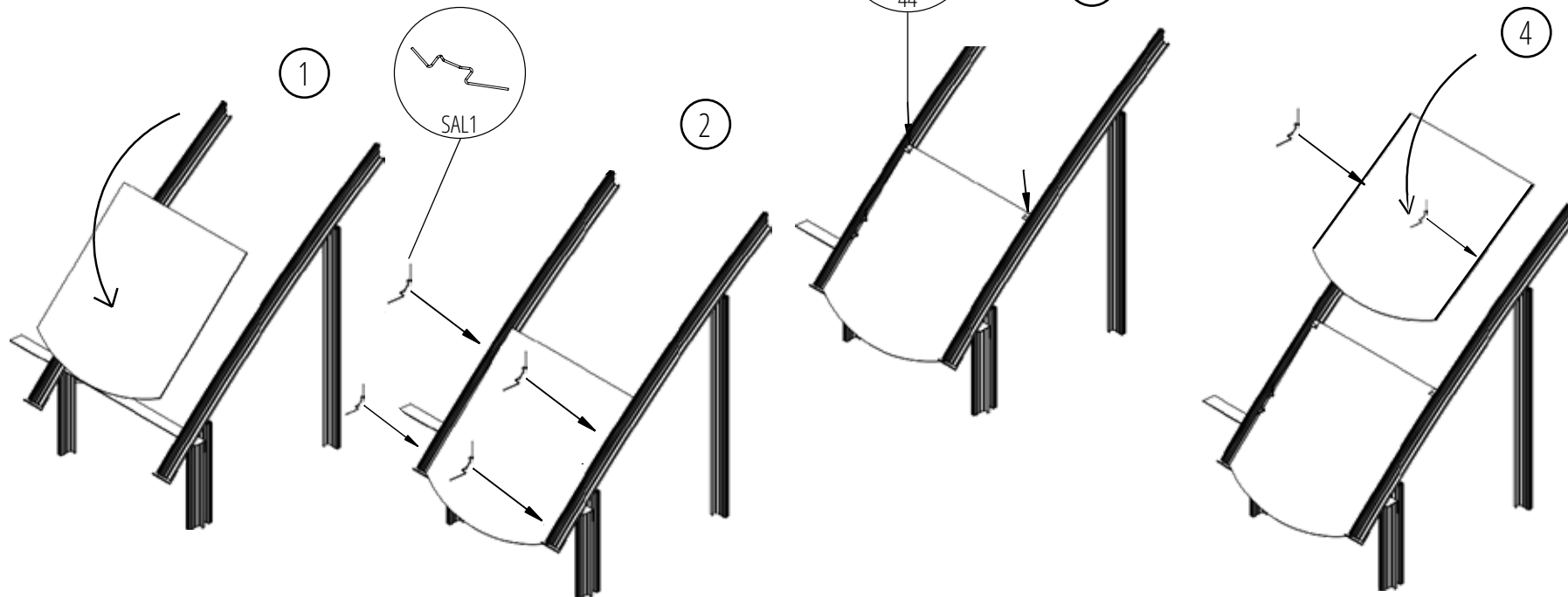
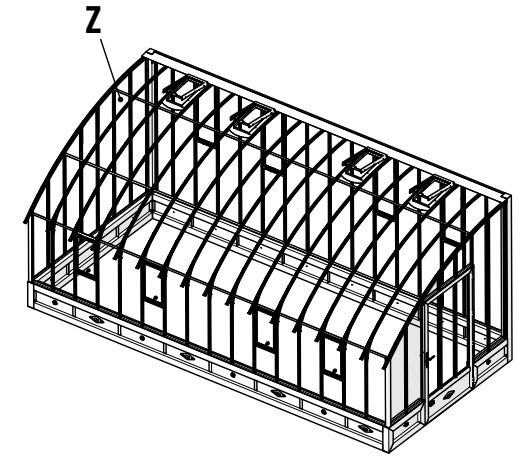
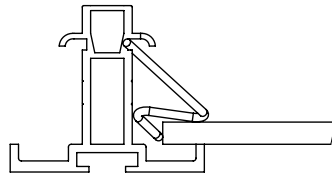
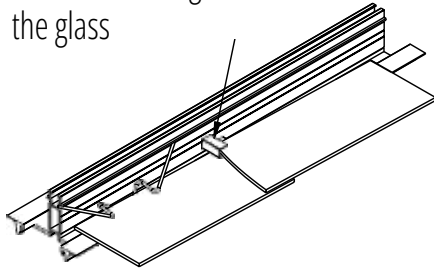

FINISHING TOUCHES

At this stage of assembly, please check that all the greenhouse hardware is correctly installed and bolted.

Fix the decorative mouldings

Fix the mouldings with screws (18) and nut cap (19).

Place the LAMS logo on the left-hand side upper part of the door aluminium panel, below the handle and lock.

The number of lead-motif and rose mouldings varies according to the size of your glasshouse. Screw them on the base plates, in the order you prefer. However, we recommend placing a leaf-motif moulding on the door and then alternate roses and leaf motifs around the glasshouse.



Leaf moulding



Rose moulding



Logo

Door frame covers

In order to hide the hinges and screws of the door frame, install door frame covers (S) on either side of the door with self-drilling screws (43).

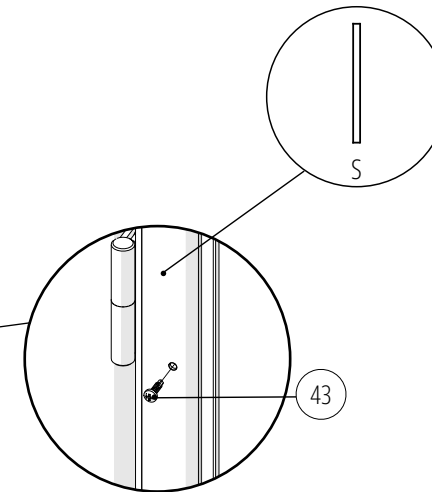
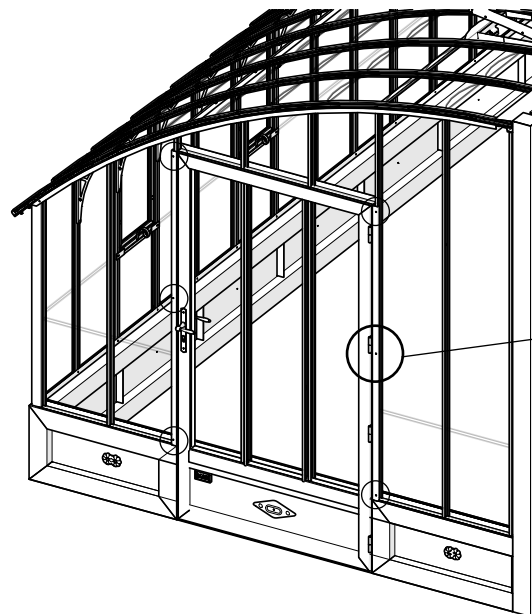

OPTION - SHADING SYSTEM

With our shading system, regulate the temperature in the glasshouse and protect plants and seedlings from direct sunrays (magnifying effect of sunrays through glass).

Purchase a shading system for your glasshouse from our website : www.serres-lams.com







French glasshouse designer & manufacturer since 1993

*DOVIRIS - 43 Avenue Georges Clémenceau 85120 LA CHÂTAIGNERAIE - FRANCE - www.serres-lams.com
Non-contractual photos and illustrations.*

